

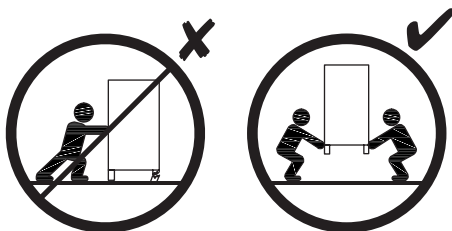

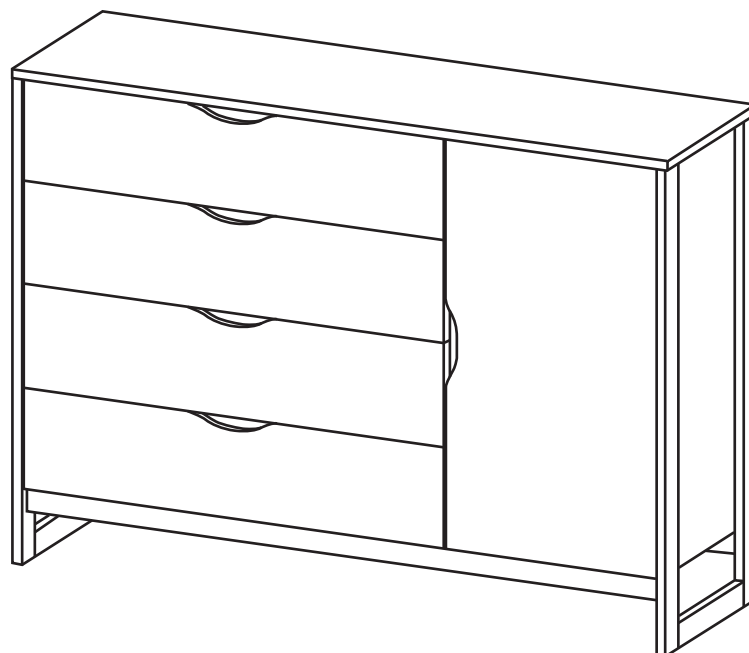



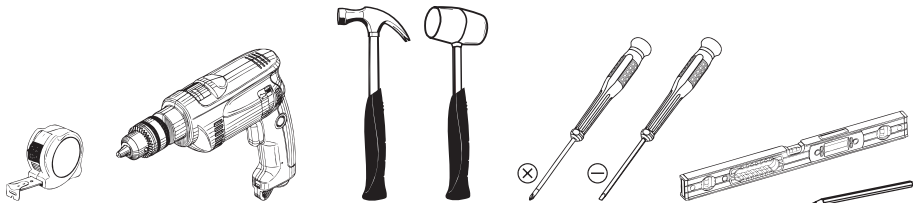

# GARDEN 1D4S/138

- Ⓧ **Montageanleitung**
- Ⓝ **Handleiding voor de montage**
- Ⓣ **Montaj talimati**
- ⓕ **Notice de montage**
- Ⓒ **Montážní návod**
- ⓗ **Szerelési útmutató**
- ⓖ **Assembly instructions**
- Ⓟ **Instrukcja montażu**
- Ⓡ **Инструкция по монтажу**
- Ⓡ **Istruzioni di montaggio**
- Ⓚ **Návod na montáž**
- Ⓡ **Instrucțiuni de montaj**
- ⓔ **Instrucciones de montaje**
- Ⓣ **Montaj Talimati**

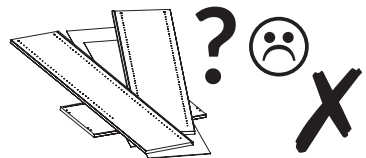

2023-09-06

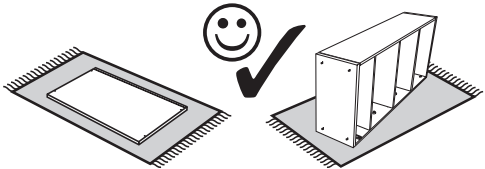
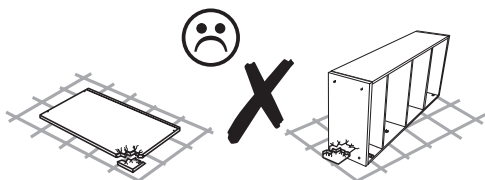
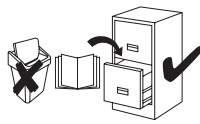
|   |  |   |   |
|---|--|---|---|
|  |    |   |  |
|  |   |    |  |
|  |  |  |   |

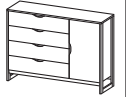

**PL** Przed rozpoczęciem montażu mebla wszystkie elementy należy sprawdzić czy nie są uszkodzone. W przypadku wykrycia uszkodzenia elementu należy odstąpić od montażu mebla i złożyć reklamację. Montaż produktu w oparciu o uszkodzone elementy oznacza akceptację ich stanu przez Kupującego, co powoduje, że reklamacja uszkodzonych elementów nie będzie uznawana.

Nie wolno przekraczać podanych maksymalnych wartości obciążenia. W innym przypadku można mebel uszkodzić lub zniszczyć.

Przed zawieszeniem mebla, lub przymocowaniem go do ściany (w celu zabezpieczenia przed przewróceniem), sprawdź wcześniej rodzaj i wytrzymałość ściany. Dołóż odpowiednie kołki i wkręty do rodzaju ściany. W przypadku wątpliwości skontaktuj się ze specjalistą. Montaż musi zostać wykonany przez osobę kompetentną.

**D** Vor Beginn der Möbelmontage sollten alle Elemente auf Beschädigungen überprüft werden. Wenn ein Element des Produkts beschädigt ist, installieren Sie das Produkt bitte nicht und reichen Sie eine Beschwerde ein. Die Installation des Produkts auf der Grundlage der beschädigten Elemente bedeutet, dass der Käufer seinen Zustand akzeptiert, was bedeutet, dass die Beschwerde über beschädigte Elemente nicht akzeptiert wird.

Überschreiten Sie die angegebenen Maximalbelastungen nicht. Andernfalls kann das Möbelstück beschädigt oder zerstört werden.

Bevor Sie ein Möbelstück an einer Wand aufhängen oder befestigen (um es gegen Umkippen zu sichern), prüfen Sie Art und Tragfähigkeit der Wand. Wählen Sie die für die Wand geeigneten Dübel und Schrauben. Im Zweifelsfall kontaktieren Sie bitte einen Fachmann. Die Montage muss durch eine sachkundige Person ausgeführt werden.

**F** Avant de commencer l'assemblage du meuble, tous les éléments doivent être vérifiés pour déceler tout dommage. Si un élément du produit est endommagé, veuillez ne pas installer le produit et déposer une plainte. L'installation du produit sur la base des éléments endommagés signifie que l'Acheteur accepte leur état, ce qui signifie que la réclamation d'éléments endommagés ne sera pas acceptée.

Ne dépassez pas les charges maximum indiquées. Sinon, le meuble peut être endommagé ou détruit.

Avant de suspendre le meuble ou de le fixer au mur (dans le but d'éviter un renversement), vérifiez au préalable le type et la résistance du mur. Utilisez les chevilles et les vis adaptées au type de mur. En cas de doute, veuillez contacter un spécialiste. Le montage doit être réalisé par une personne compétente.

**CZ** Před zahájením montáže nábytku je třeba zkontrolovat poškození všech prvků. Pokud je některý prvek produktu poškozen, zdržte se instalace produktu a podejte stížnost. Instalace výrobku na základě poškozených prvků znamená, že kupující akceptuje jejich stav, což znamená, že reklamační požadavky na poškozených prvcích nebude uznána.

Nepřekračujte uvedené maximální zatížení. V opačném případě může dojít k poškození nebo zničení nábytku.

Před zavěšením nábytku nebo jeho připevněním ke zdi (za účelem zajištění před převrácením) dřívě zkontrolujte druh a odolnost stěny. Vyberte k druhu stěny vhodné hmoždinky a šrouby. V případě pochybností kontaktujte specialistu. Montáž musí být provedena kompetentní osobou.

**HU** A bútor szerelés megkezdése előtt ellenőrizni kell az összes elem sérülését. Ha a termék bármely eleme megsérült, kérjük, tartózkodjon a termék telepítésétől és nyújtson be panaszt. A termék sérült elemek alapján történő felszerelés azt jelenti, hogy a Vevő elfogadja azok állapotát, ami azt jelenti, hogy a sérült elemek igényét nem fogadják el.

A megadott maximális terhelési értékeket nem szabad túllépni. Ellenkező esetben a bútor megsérülhet vagy megsemmisülhet.

A bútor felfüggesztése illetve falhoz való rögzítése (megakadályozván ezzel eldőlésének lehetőségét) előtt ellenőrizze a fal fajtaját és szilárdságát. Megfelelő, a falhoz illő tipliket és csavarokat használjon. Ha kétsége támadna, konzultáljon szakemberrel. A felszerelést csakis egy hozzáértő szakember végezheti el.

**GB** Before starting the furniture assembly, all elements should be checked for damage. If any element of the product is damaged, please refrain from installing the product and file a complaint. Installation of the product on the basis of the damaged elements means the Buyer's acceptance of their condition, which means that the complaint of damaged elements will not be accepted.

The specified maximum load values must not be exceeded. Otherwise, the piece of furniture may be damaged or destroyed.

Before suspending or fixing furniture to the wall (in order to prevent falling over), check the type and strength of the wall. Select wall plugs and screws appropriate for the given type of the wall. In the case of doubts, contact a specialist. The installation must be performed by a competent person.

**SK** Pred začatím montáže nábytku je za mali skontrolovať všetky prvky, či nie sú poškodené. Ak je niektorý prvok výrobku poškodený, neinstalujte výrobok a reklamujte ho. Inštalácia produktu na základe poškodených prvkov znamená, že Kupujúci akceptuje ich stav, čo znamená, že reklamácia poškodených prvkov nebude akceptovaná.

Uvedené hodnoty maximálneho zaťaženia nesmú byť prekročené. V opačnom prípade môže dôjsť k poškodeniu alebo zničeniu nábytku.

Pred zavesením nábytku alebo jeho pripavením na stenu (za účelom zaistenia pred prevrátením) predtým skontrolujte druh a odolnosť steny. Vyberte k druhu steny vhodné hmoždinky a skrutky. V prípade pochybností kontaktujte specialistu. Montáž musí byť vykonaná kompetentnou osobou.

**RU** Перед началом сборки мебели следует проверить все элементы на предмет повреждений. Если какой-либо элемент продукта поврежден, пожалуйста, воздержитесь от установки продукта и подайте жалобу. Установка товара на поврежденные элементы означает, что Покупатель принимает их состояние, а значит, претензии по поврежденным элементам не принимаются.

Указанные максимальные значения нагрузок не должны превышать. В противном случае предмет мебели может быть поврежден или уничтожен.

Перед подвешиванием мебели или ее креплением к стене (для защиты от падений) проверьте предварительно тип и прочность стены. Подберите соответствующие типу стены дюбели и шурупы. При возникновении сомнений свяжитесь со специалистом. Монтаж должен проводиться компетентным лицом.

**IT** Prima di iniziare l'assemblaggio del mobile, tutti gli elementi dovrebbero essere controllati per danni. Se qualche elemento del prodotto è danneggiato, astenersi dall'installare il prodotto e presentare un reclamo. L'installazione del prodotto sulla base degli elementi danneggiati implica l'accettazione da parte dell'Acquirente della loro condizione, il che significa che il reclamo per elementi danneggiati non sarà accettato.

I valori di carico massimo specificati non devono essere superati. In caso contrario, il mobile potrebbe essere danneggiato o distrutto.

Prima di appendere i mobili, oppure attaccarli al muro (per proteggerli da ribaltamenti), verifica prima la tipologia e resistenza del muro. Scegli i tasselli e viti più adatti per il tipo di muro. In caso di dubbi contattare uno specialista. Il montaggio deve essere fatto da una persona competente.

**NL** Voordat u met de meubelmontage begint, moeten alle elementen op schade worden gecontroleerd. Als een onderdeel van het product beschadigd is, installeer het dan niet en dien een klacht in. Installatie van het product op basis van de beschadigde elementen betekent dat de koper hun staat accepteert, wat betekent dat de claim voor beschadigde elementen niet wordt geaccepteerd.

Overschrijd de aangegeven maximale belastingen niet. Anders kan het meubelstuk worden beschadigd of vernield.

Voordat u het meubel ophangt of bevestigt tegen de muur (om het te beschermen tegen omvallen) dient u het type en de duurzaamheid van deze muur na te kijken. Maak gebruik van pluggen en schroeven die geschikt zijn voor het type muur. Neem in geval van twijfels contact op met een specialist. De assemblage dient te worden uitgevoerd door iemand met kennis van zaken.

**TR** Mobilya montajına başlamadan önce tüm elemanlarda hasar olup olmadığının kontrol edilmelidir. Ürünün herhangi bir parçası hasar görmüşse, lütfen ürünü kurmayın ve şikayete bulunun. Ürünün hasarlı elemanlar bazında montajı, Alıcının durumunu kabul ettiği anlamına gelir, bu da hasarlı elemanlar için talep kabul edilmeyeceği anlamına gelir.

Belirtilen azami yük degerini aşmayınız, aksi takdirde mobilya parçaları zarar görebilir veya kullanılamaz hale gelebilir.

Mobilyayı duvara asmadan veya montaj etmeden önce (devrilmesini önlemek için) duvarın türünü ve dayanıklılığını kontrol edin. Duvara uygun dübelleri ve vidaları seçin. Emin olamamanız durumunda bir uzman ile irtibata geçin. Kurulum yetkili bir kişi tarafından yapılmalıdır.

**RO** Înainte de a începe asamblarea mobilierului, toate elementele trebuie verificate pentru a nu se deteriora. Dacă vreun element al produsului este deteriorat, vă rugăm să vă abțineți de la instalarea produsului și să depuneți o reclamație. Instalarea produsului pe baza elementelor deteriorate înseamnă acceptarea de către Cumpărător a stării lor, ceea ce înseamnă că reclamația privind elementele deteriorate nu va fi acceptată.

Valorile maxime de sarcină specificate nu trebuie depășite. În caz contrar, piesa de mobilier poate fi deteriorată sau distrusă.

Înainte de suspendarea unei piese de mobilier sau atașarea acesteia la perete (pentru a preveni bascularea), verificați în prealabil tipul și gradul de rezistență a peretelui. Montați diblurile și șuruburile adecvate pentru tipul de perete. În caz de îndoieli, consultați un specialist. Instalarea trebuie să fie efectuată de către o persoană competentă.

**ES** Antes de comenzar el montaje de los muebles, todos los elementos deben comprobarse en busca de daños. Si algún elemento del producto está dañado, absténgase de instalar el producto y presente una queja. La instalación del producto sobre la base de los elementos dañados supone la aceptación por parte del Comprador de su estado, por lo que no se aceptará la reclamación de elementos dañados.

No se deben exceder los valores de carga máxima especificados. De lo contrario, el mueble puede dañarse o destruirse.

Antes de colgar o fijar el mueble en el muro (a fin de proteger contra el vuelco del mueble), compruebe de antemano la naturaleza y la resistencia de la pared. Seleccione tacos y tornillos adecuados para el tipo de la pared. En caso de duda, consulte a un especialista, debiendo efectuar este montaje una persona competente.

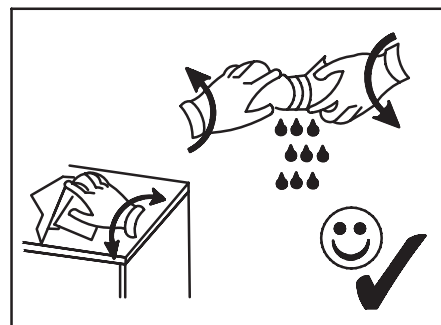
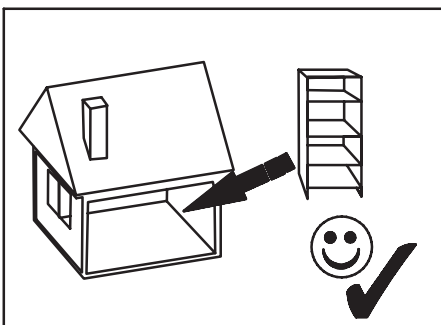
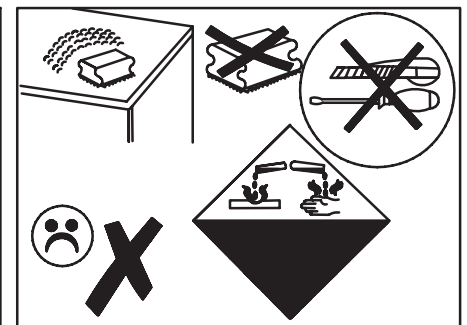
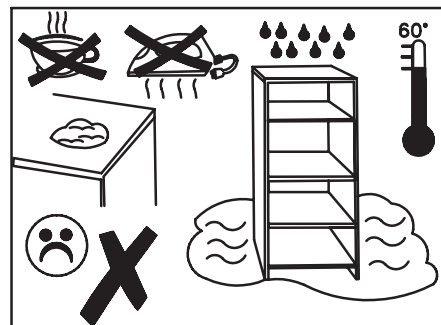
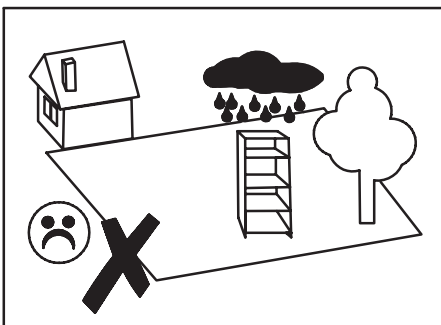



|                                |                                |                                |                                   |                                 |                                  |
|--------------------------------|--------------------------------|--------------------------------|-----------------------------------|---------------------------------|----------------------------------|
| <b>A</b><br><br>7 x 50 mm x 10 | <b>B</b><br><br>8 x 32 mm x 36 | <b>C</b><br><br>(P/D) x 6      | <b>E</b><br><br>3,5 x 13 mm x 5   | <b>E2</b><br><br>3 x 20 mm x 16 | <b>EP2</b><br><br>4 x 20 mm x 48 |
| <b>G2</b><br><br>x 4           | <b>H1</b><br><br>x 7           | <b>K6</b><br><br>L=350 mm x 4  | <b>T4</b><br><br>6,3 x 24 mm x 12 | <b>P</b><br><br>x 4             | <b>R</b><br><br>H=11 mm x 18     |
| <b>RB</b><br><br>x 16          | <b>T3</b><br><br>5 x 9 mm x 32 | <b>U</b><br><br>L=24,3 mm x 18 | <b>W1</b><br><br>x 1              | <b>XA</b><br><br>x 1            | <b>ZA</b><br><br>Ø4 x 8          |
| <b>ZR</b><br><br>Ø15 x 18      |                                |                                |                                   |                                 |                                  |

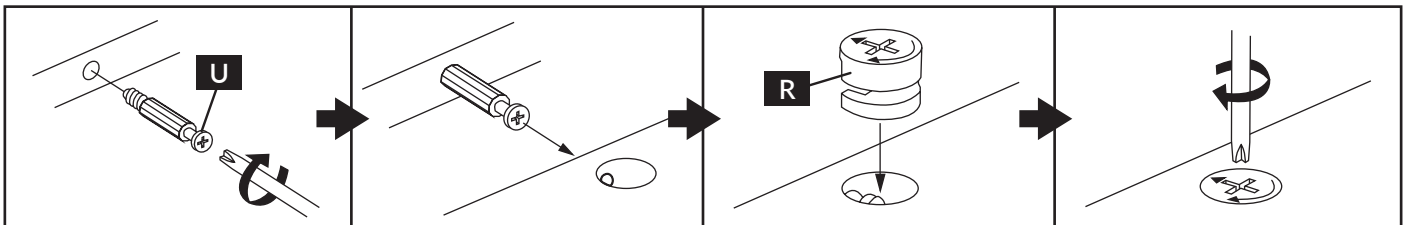
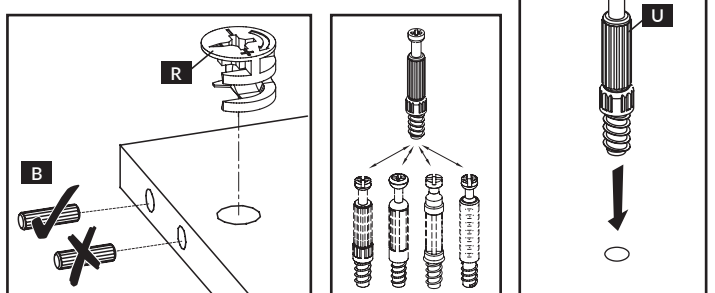
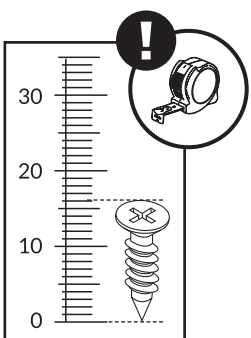
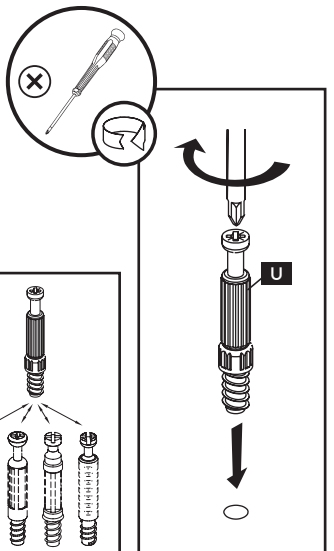
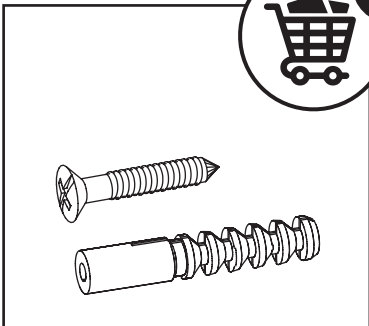

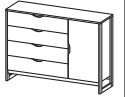

| nr   | ↔ [mm] | ↑ [mm] | ∅ [mm] | Menge | Colli |
|------|--------|--------|--------|-------|-------|
| G-1  | 1340   | 50     | 15     | x2    | 1/2   |
| G-2  | 294    | 50     | 15     | x2    | 1/2   |
| G-3  | 972    | 50     | 15     | x2    | 2/2   |
| G-4  | 972    | 50     | 15     | x2    | 2/2   |
| G-5  | 1308   | 359    | 16     | x1    | 1/2   |
| G-6  | 430    | 340    | 16     | x1    | 1/2   |
| G-7  | 1378   | 396    | 16     | x1    | 1/2   |
| G-8  | 822    | 374    | 16     | x1    | 2/2   |
| G-9  | 806    | 359    | 16     | x1    | 2/2   |
| G-10 | 822    | 374    | 16     | x1    | 2/2   |
| G-11 | 446    | 820    | 16     | x1    | 2/2   |
| G-12 | 1322   | 830    | 3      | x1    | 1/2   |
| G-13 | 886    | 202    | 16     | x4    | 1/2   |
| G-14 | 806    | 120    | 16     | x4    | 1/2   |
| G-15 | 350    | 120    | 16     | x4    | 1/2   |
| G-16 | 350    | 120    | 16     | x4    | 1/2   |
| G-17 | 838    | 357    | 3      | x4    | 2/2   |

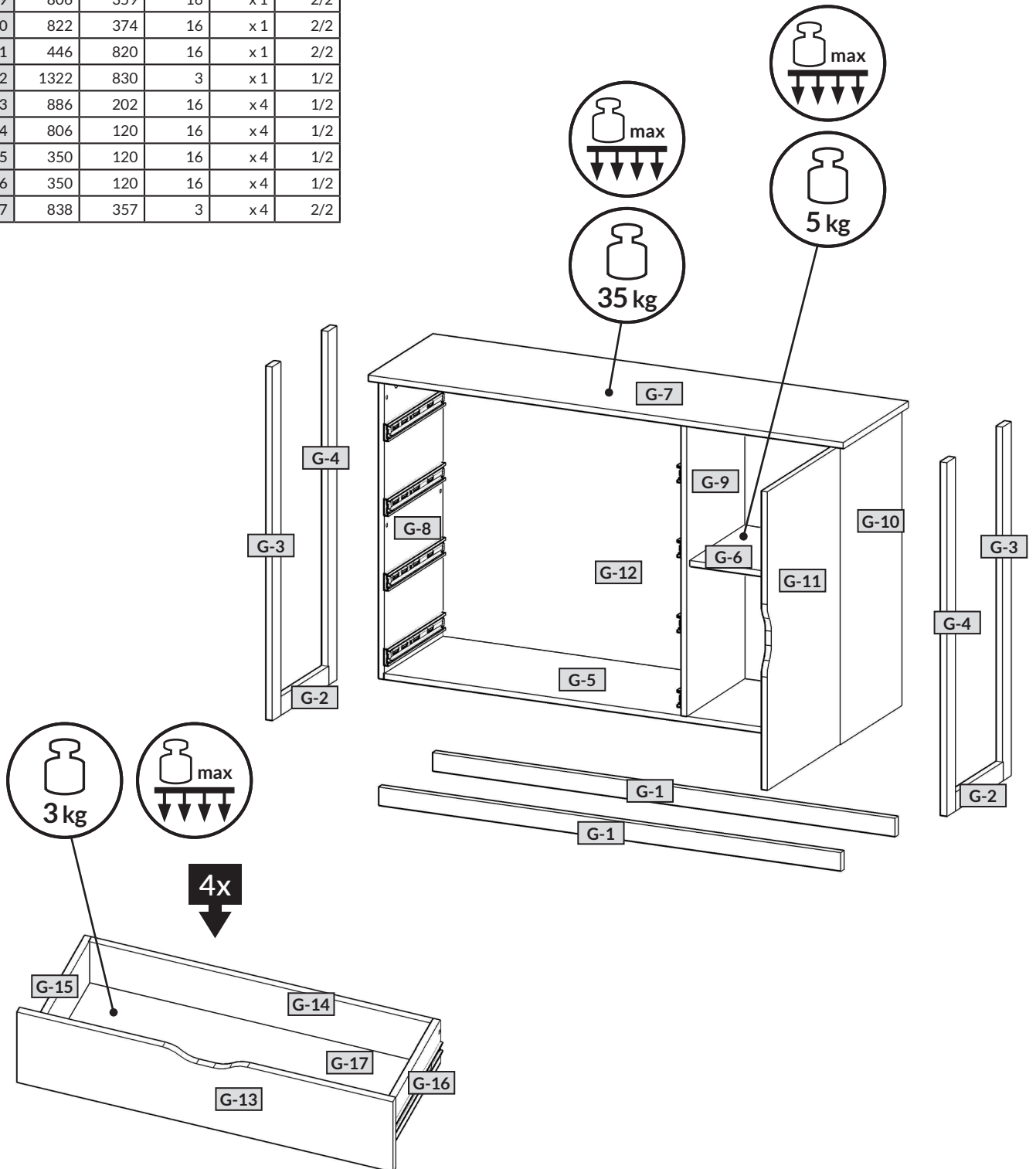





## 1

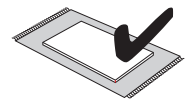
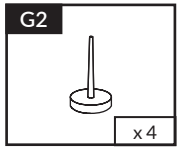
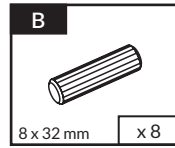
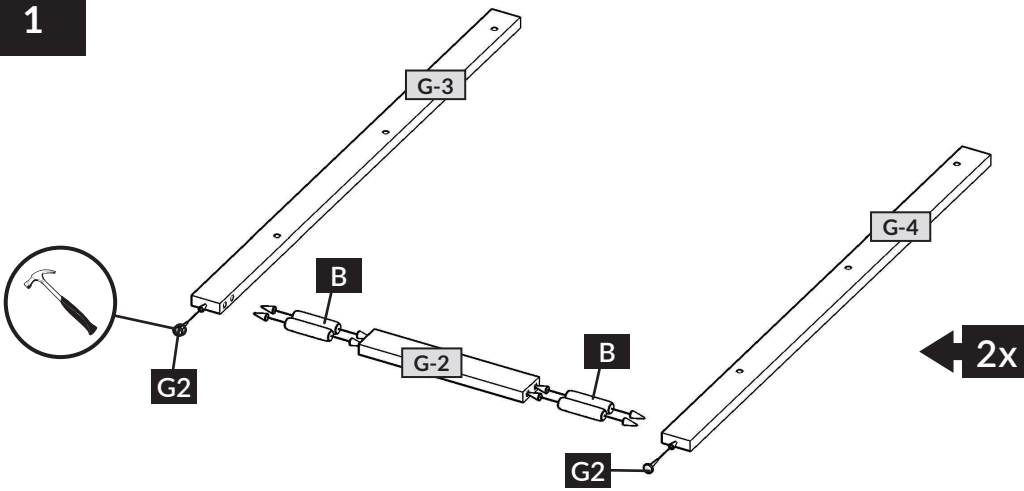

## 2

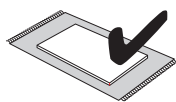
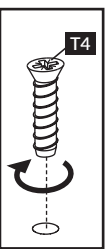
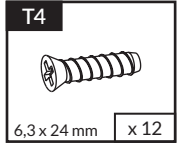
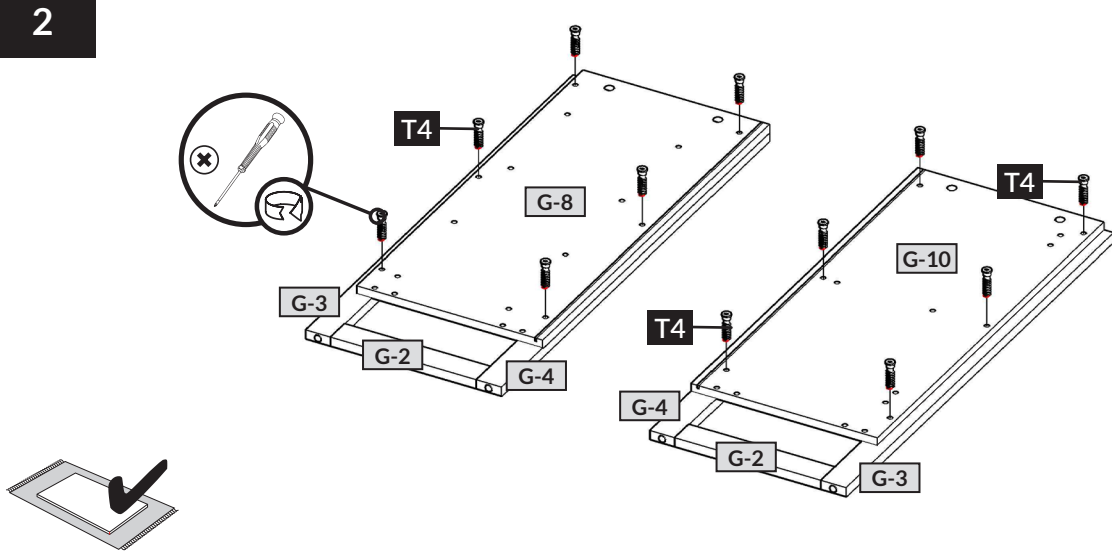

## 3

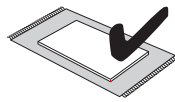
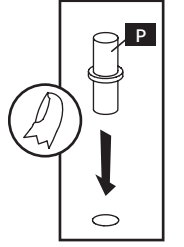
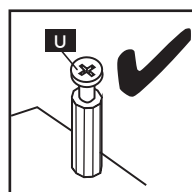
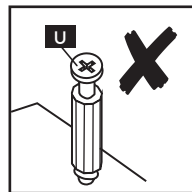
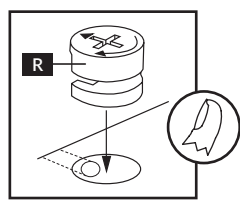
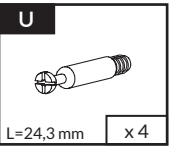
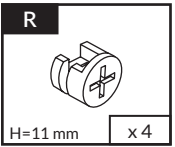
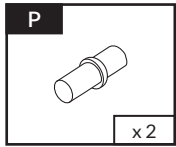
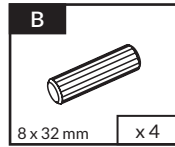
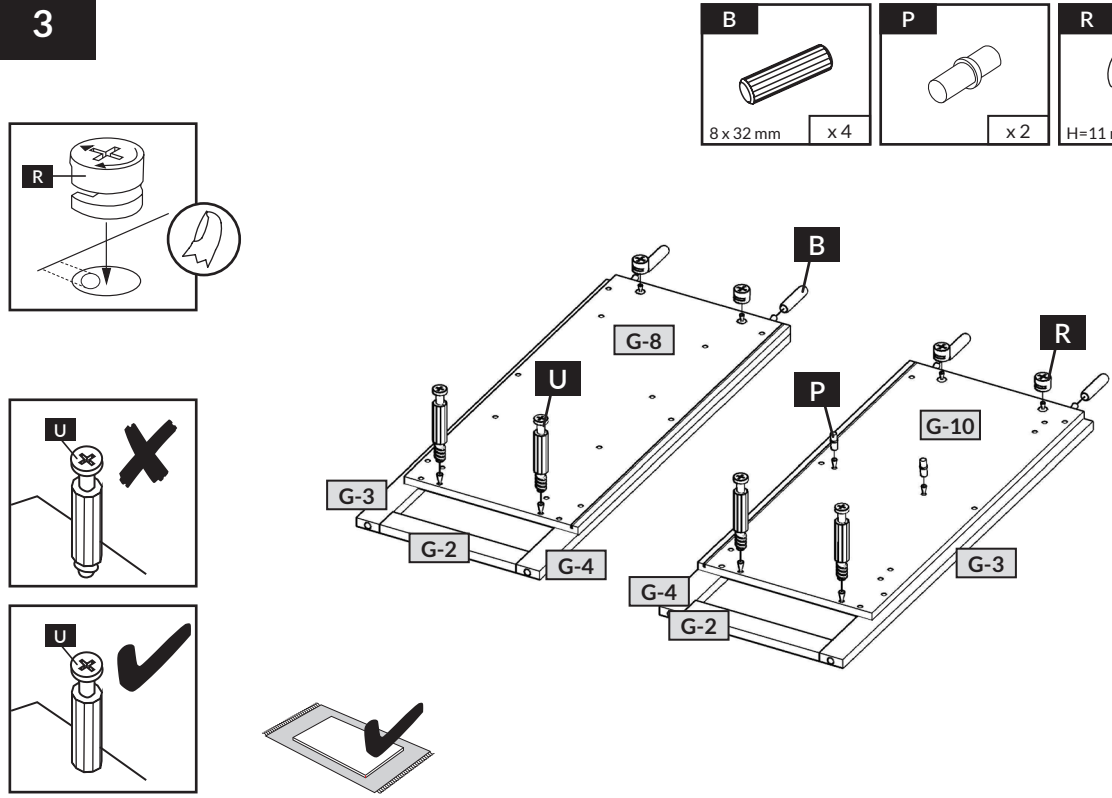



## 4

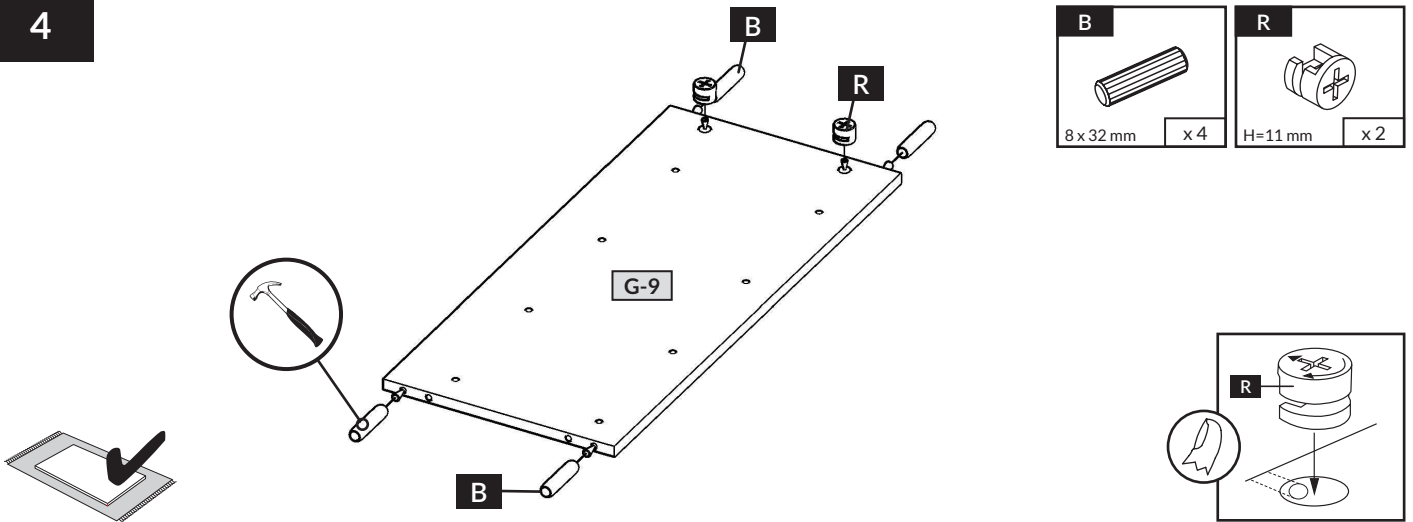

## 5

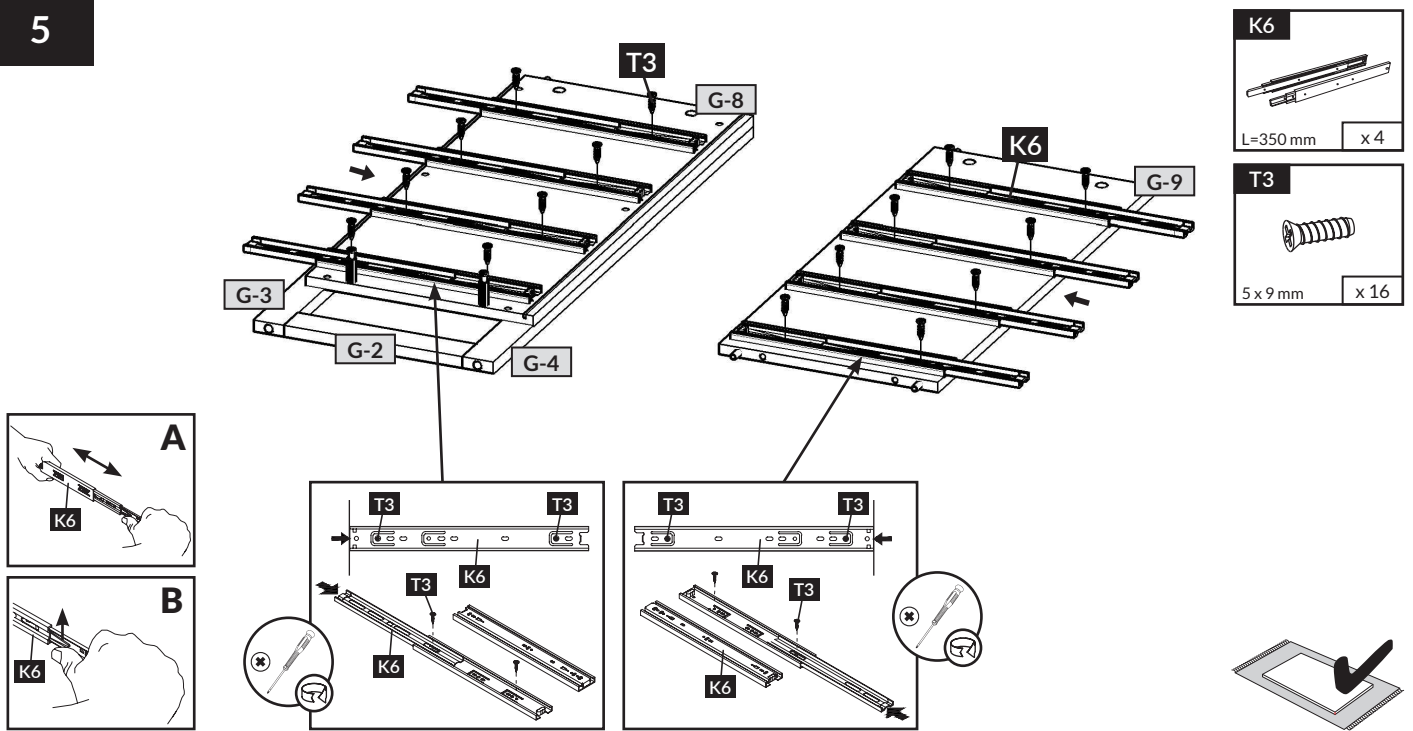

## 6

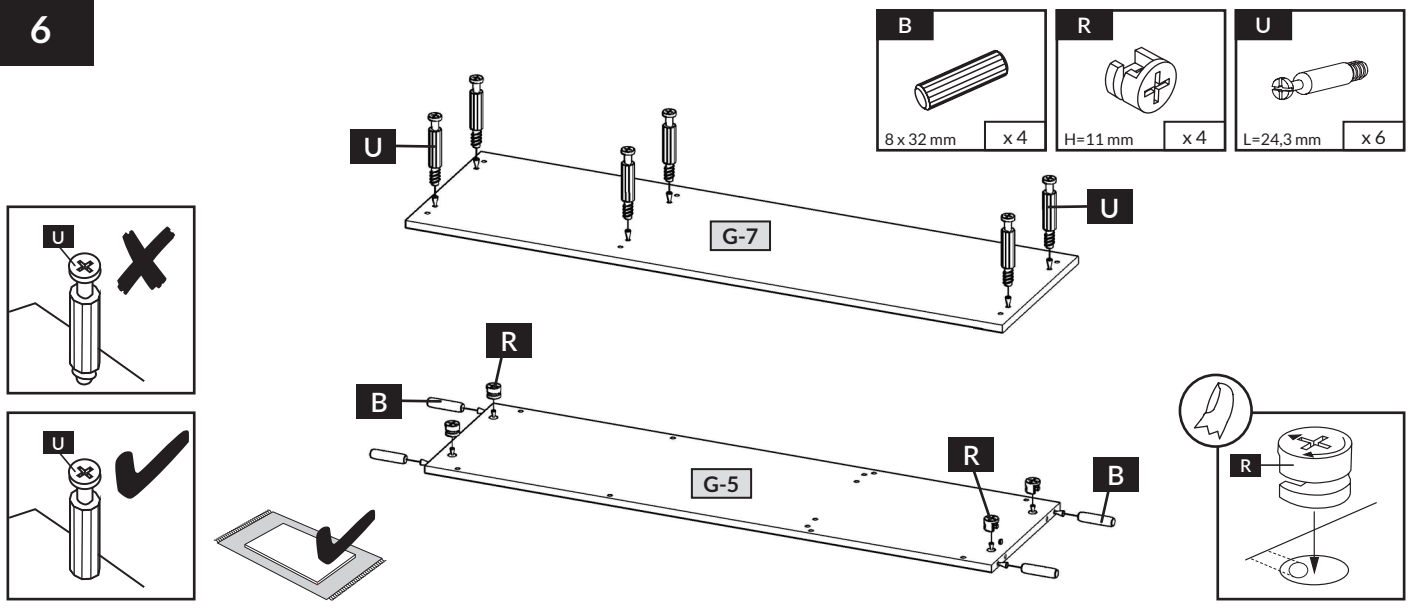

7

# GARDEN 1D4S/138



7

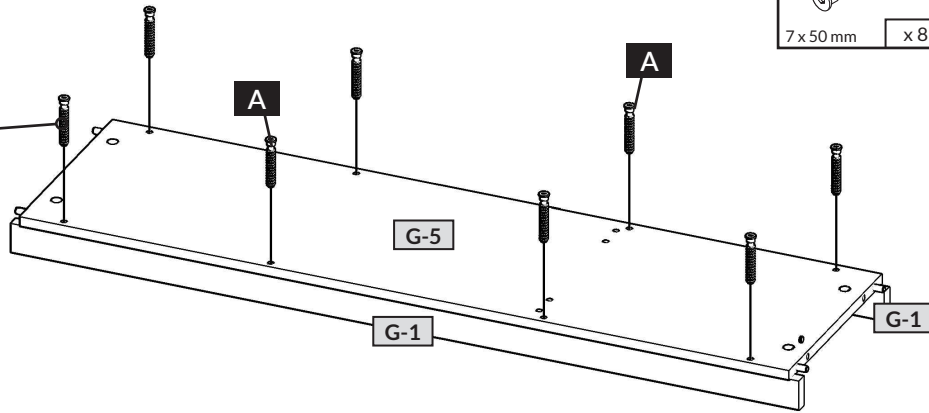
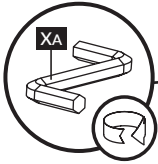
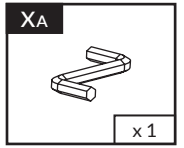
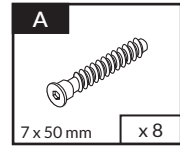

8

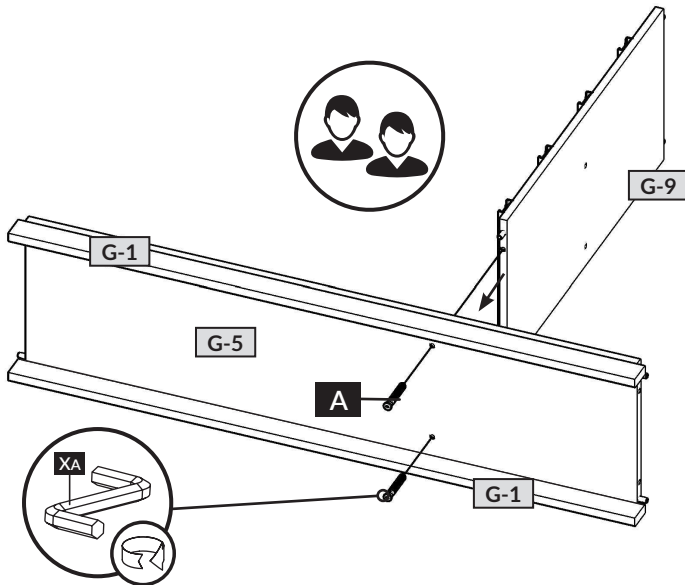
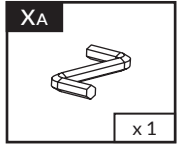
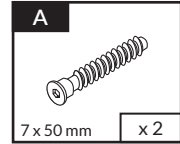

9

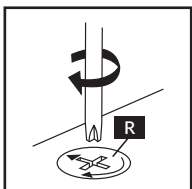
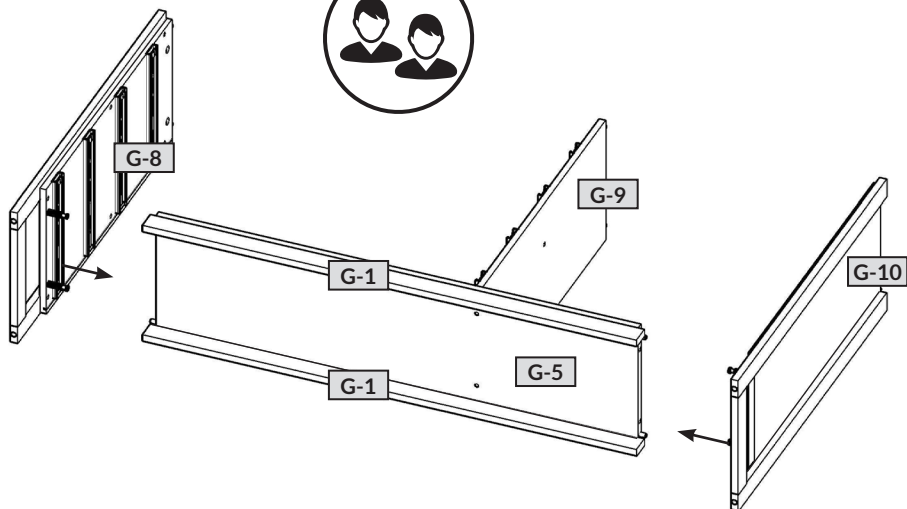



## 10

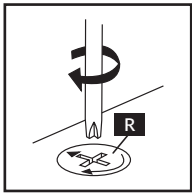
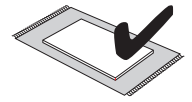
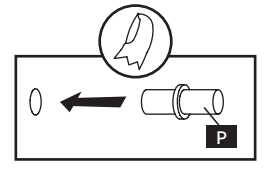
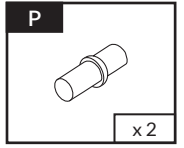
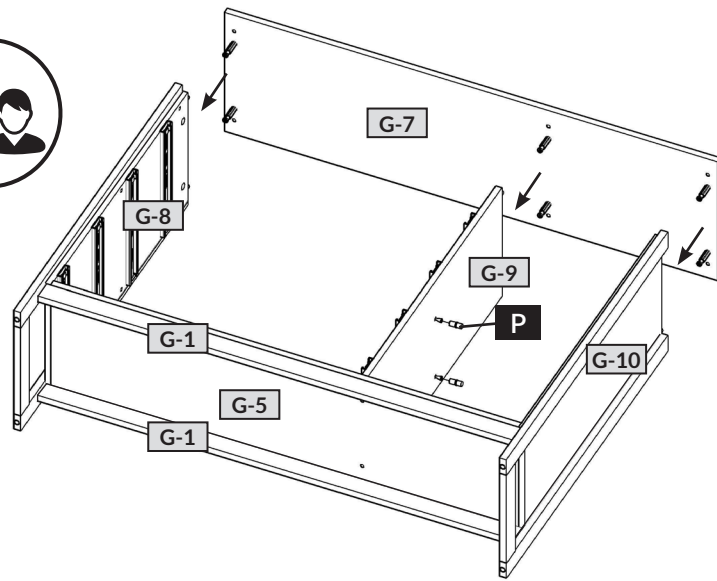

## 11

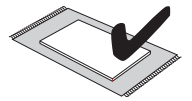
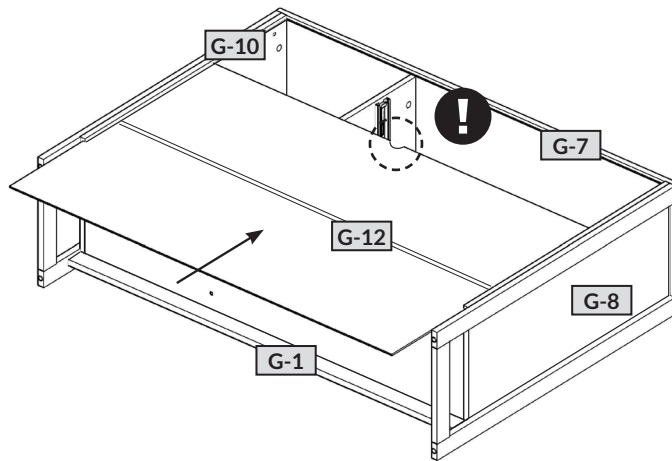

## 12

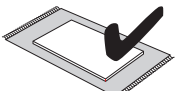
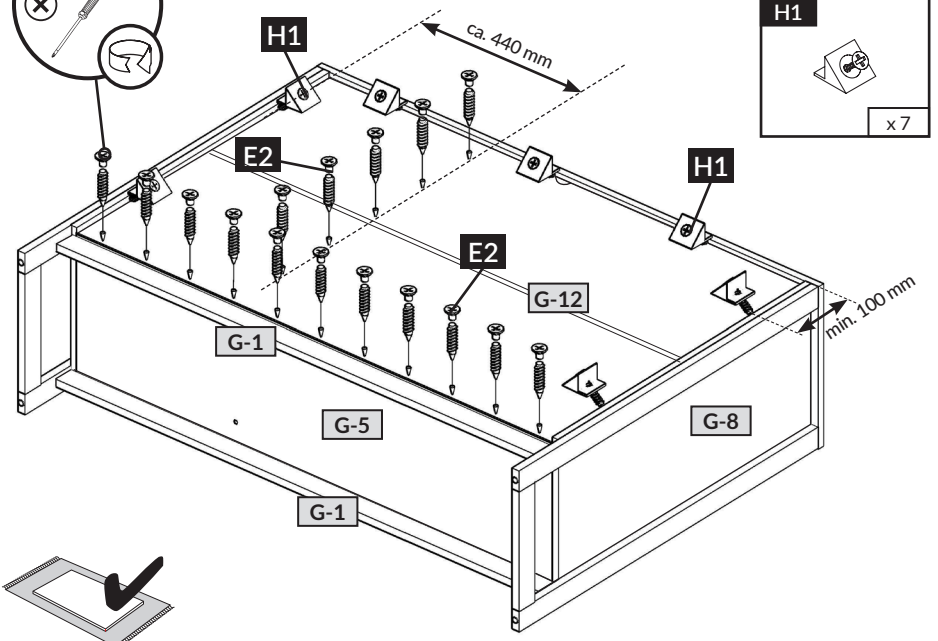
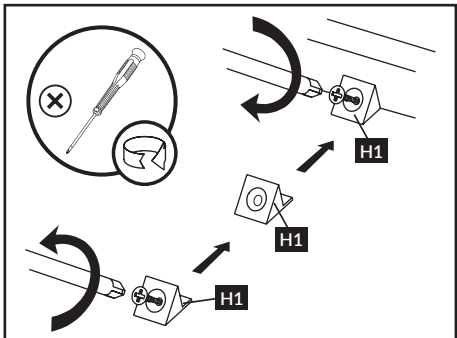
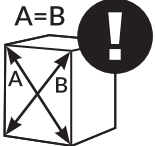
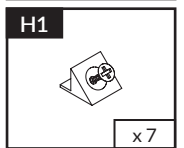
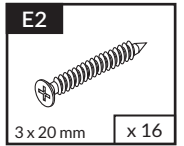
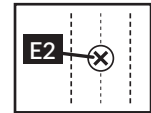



## 13

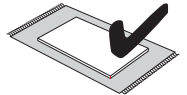
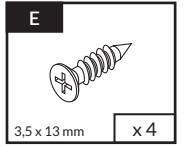
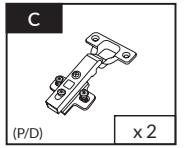
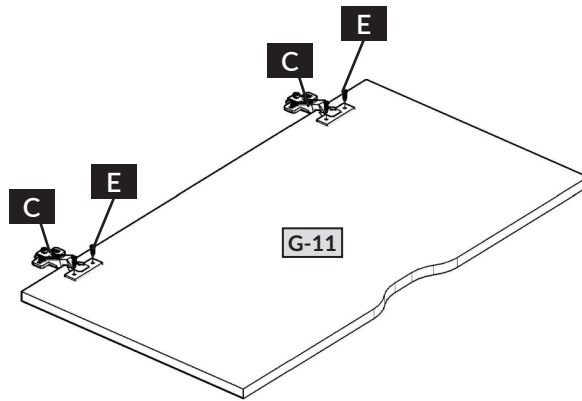
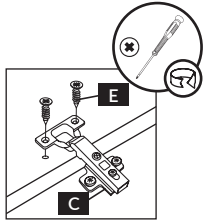

## 14

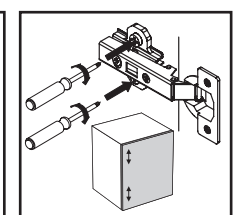
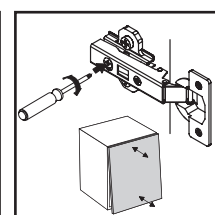
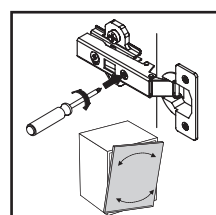
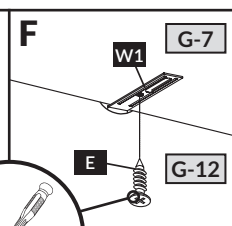
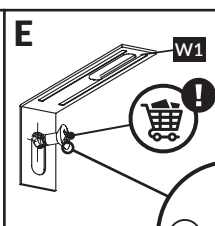
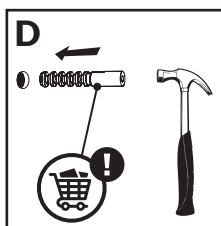
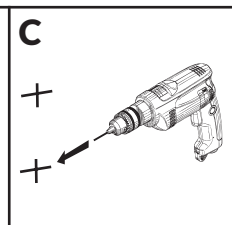
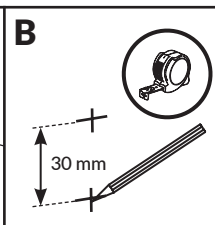
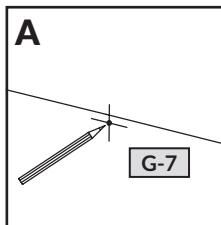
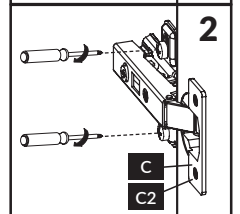
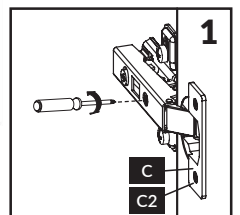
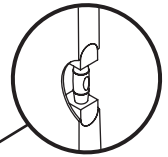
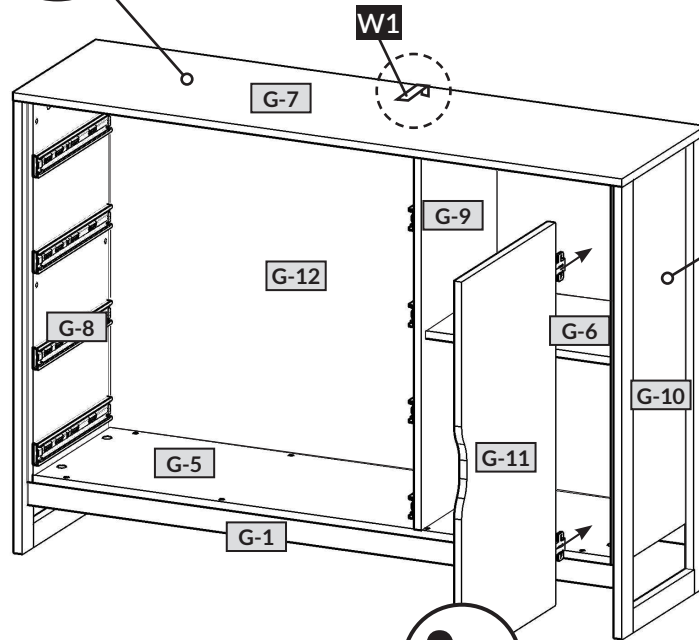
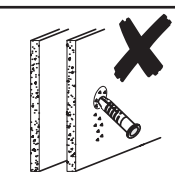
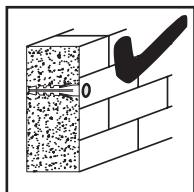
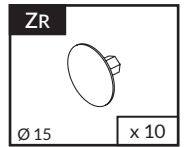
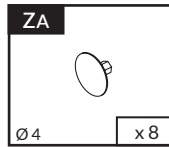
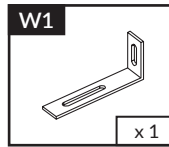
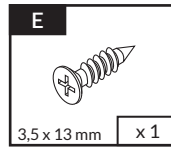
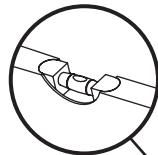
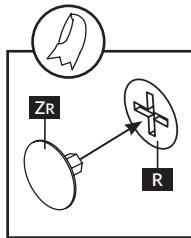
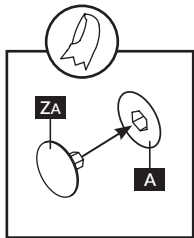

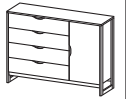

15

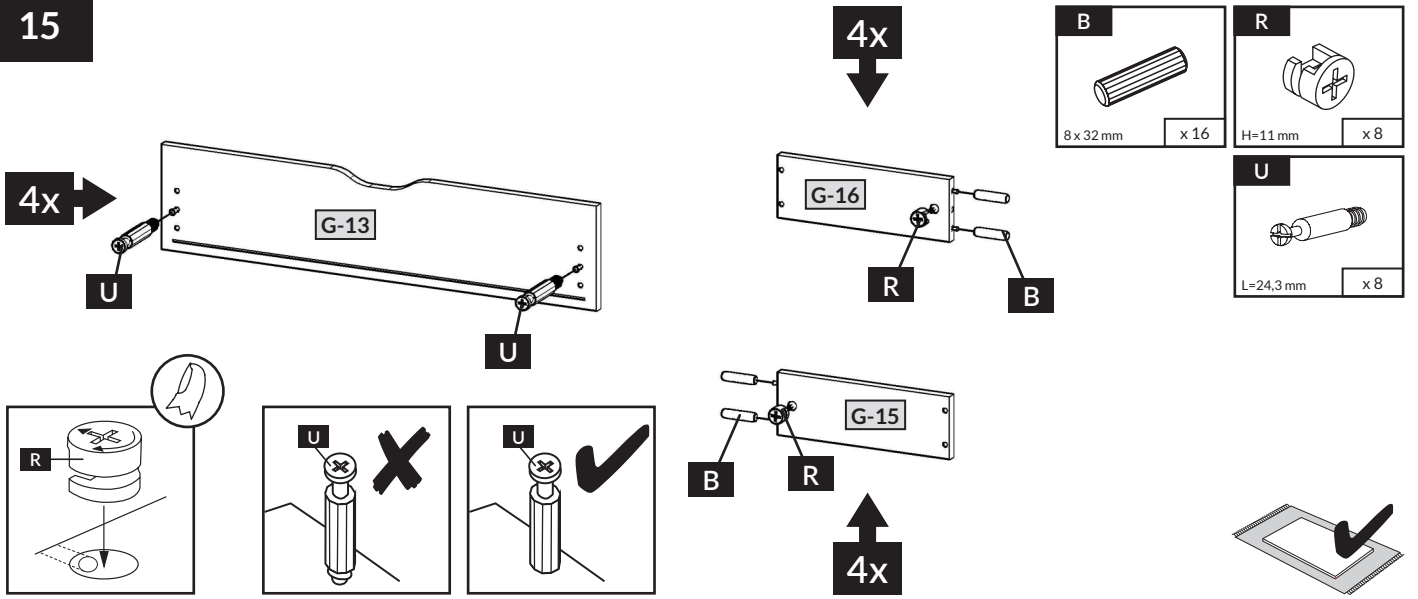

16

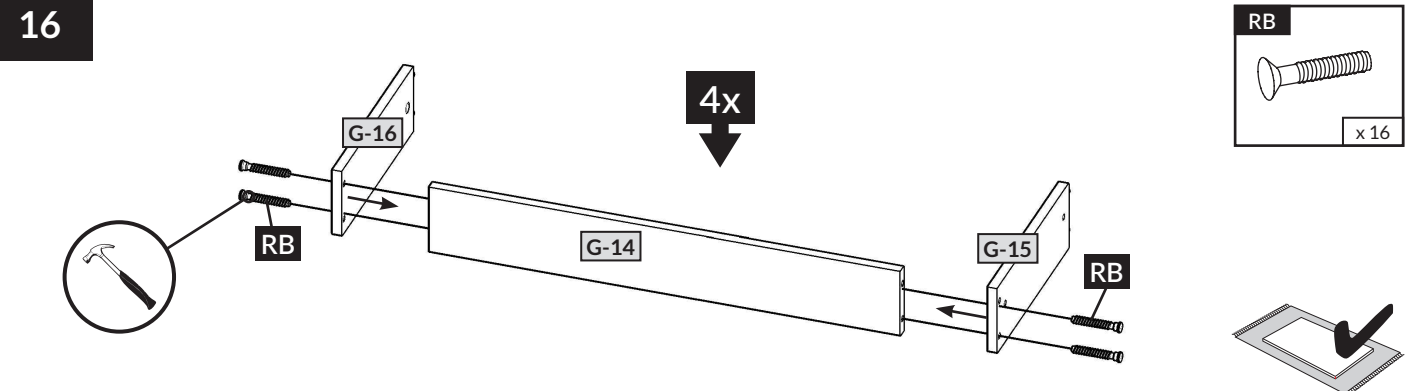

17

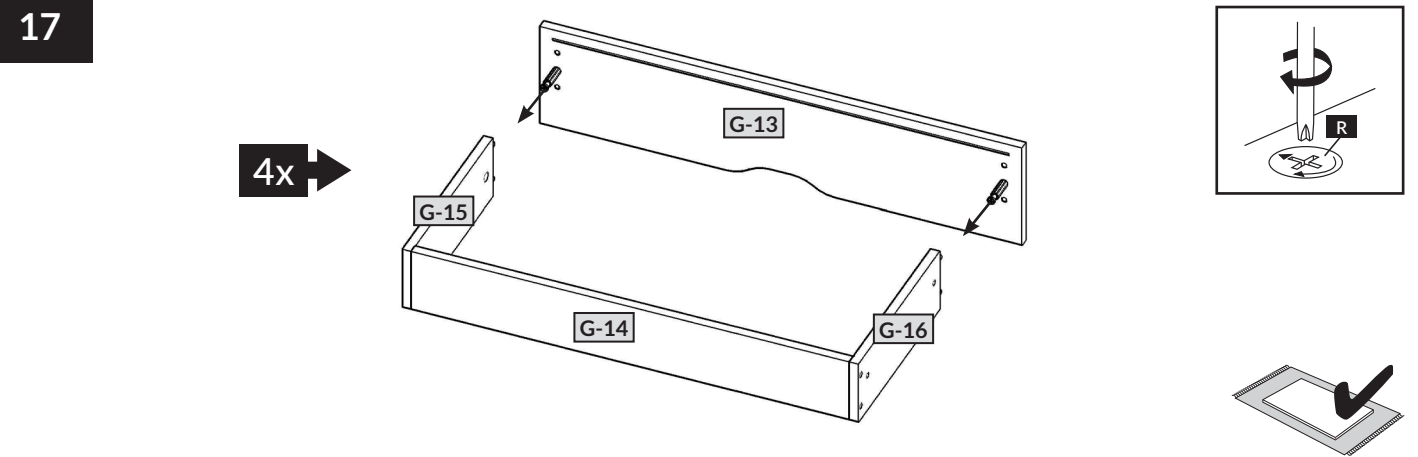

18

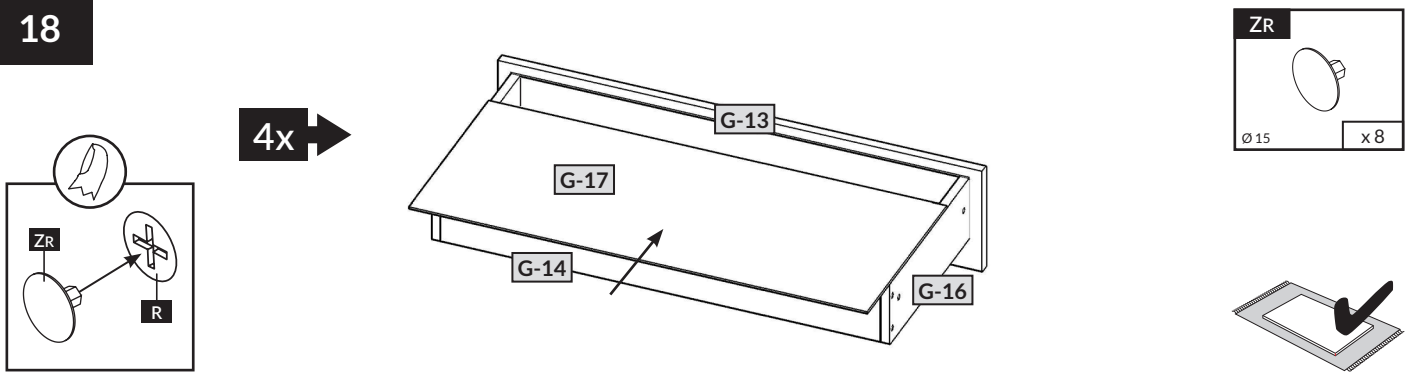

11

# GARDEN 1D4S/138

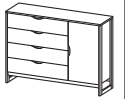

19

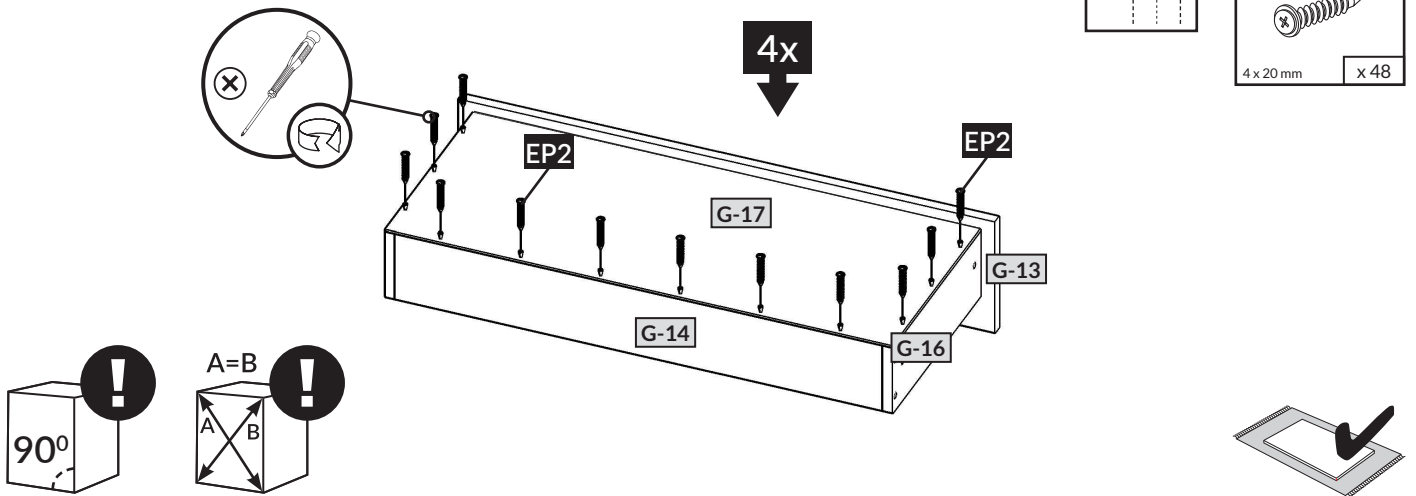

20

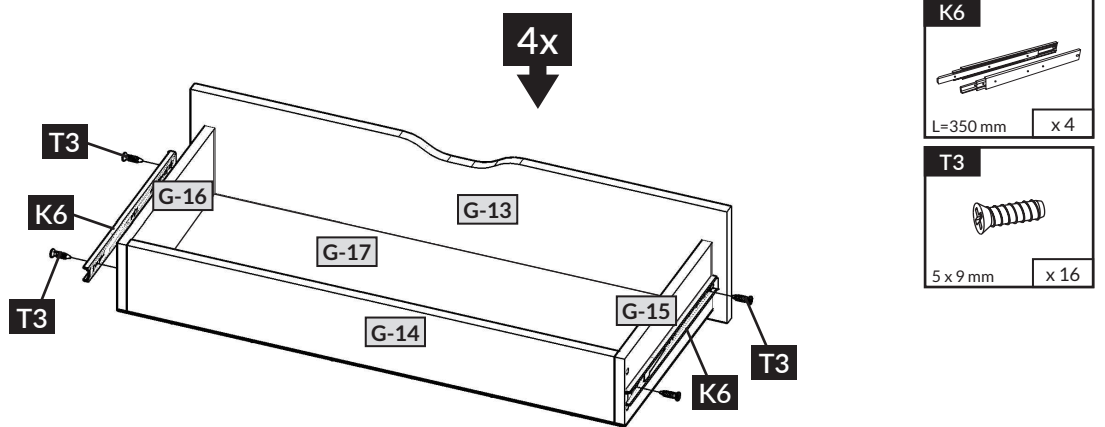

21

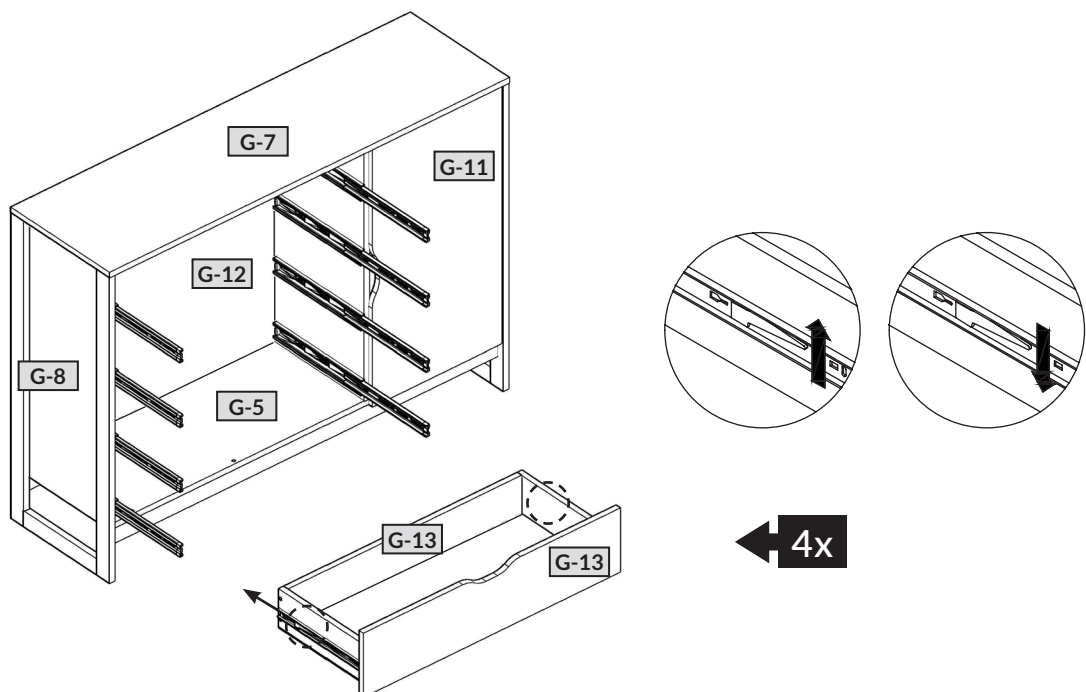



Name • Nom • Nome • Naam • Nazwa • Иméно  
• Názov • Név • Denumire • Isim • Извание

Nr • No • N° • Номер • Č • Sz

Typ • Type • Tip • Típus • Tipo • Tun

GARDEN

— —

1D4S/138

D

Unser Direktservice für Beschlagteile  
Sollte Ihnen ein Beschlagteil fehlen, können Sie diese Servicekarte  
direct an die untenstehende Nummer senden. Wir können allerdings  
nur Beschlagteile auf diesem Weg verschicken. Sollen Sie eine andere  
Beanstandung an Ihrem Möbelstück haben, so wenden Sie sich bitte  
direkt an Ihr Möbelhaus.

GB

Our direct order service for fitting  
If a fitting should be missing to you, you know this service map  
directly following number faxes. We can in this way send away  
however only fitting. If you should have another objection to your  
piece of furniture, then they turn please to your furniture house.

CZ

Naše přímé služby pro kování  
Chybí-li vám nějaký díl z kování, můžete tuto servisní kartu odfaxovat  
přímo na níže uvedené číslo. Touto cestou však můžeme zoslat jen  
díly kování. Pokud byste reklamovali jiný díl nábytku, obraťte se přímo  
na svého prodejce nábytku.

F

Bien étudier la notice de montage  
Repérez les pièces constituant votre meuble. Regroupez et contrôlez la  
quincaillerie. Munissez - vous de l'outillage nécessaire. Aménagez -  
vous une zone de montage. Procédez au montage. Ne jamais forcer  
les assemblages. Resserrez les vis après quelques temps d'usage.  
Gardez votre notice de montage, si une pièce venait à manquer, elle  
serait le plus clair moyen de communiquer avec votre magasin.

I

Il nostro servizio diretto per l'ordine della ferramenta  
Nel caso vi mancassero dei pezzi, potete spedire fax questa carta di  
servizi direttamente al seguente numero. Per altri reclami al vostro  
mobile, potete rivolgervi al vostro mobilificio.

BG

Директно обслужаване на електрични делци "Обзор"  
Ако ви недостига некои од делцима молимо вас да на дојде  
наведениот број број посетите овој сервисни образац. На овој начин могу  
е доставити само делци. У случају да имате додатне приговоре везани  
уз комода најместајте молимо вас да се обраќате изравно трговини  
најместајте гојје је исти купител.

NL

Onze directservice voor losse onderdelen  
Wanneer er een onderdeel mist kunt u deze servicekaart direct aan  
onderstaand faxnummer sturen. Wij kunnen alleen langs deze weg  
onderdelen versturen. Mocht u een ander probleem aan uw meubel  
hebben verzeken wij u contact op te nemen met uw meubeldealer.

PL

Nasz bezpośredni serwis części montażowych  
Jeżeli brakuje części koniecznych do montażu, prosimy o przesłanie  
nam tej karty serwisowej na niżej podany numer faxu. Możemy w ten  
sposób przysłać państwu tylko brakujące części. W przypadku innych  
objętości dotyczących mebla, prosimy o zgłoszenie ich do salonu  
meblowego w którym został dokonany zakup.

HR

Servis za okove  
U slučaju da nedostaje neki od dijelova molimo vas da na dođe  
navedeni broj broja posetite ovaj servisni obrazac. Na ovaj način mogu  
se dostaviti samo okovi. U slučaju da imate dodatne prigovore vezane  
uz komodu najmestajte molimo vas da se obratite izravno trgovini  
najmestajte gojje je isti kupitelj.

HU

Direktszolgálatunk vasalatok esetén  
Ha hiányzik egy vasalat, ezt a kártyát közvetlenül elfaxolhatja az alább  
található faxszámra. Azonban csak vasalatokat tudunk így küldeni.  
Amennyiben másféle reklamációt áll fenn bútordarabjait illetően,  
forduljon közvetlenül a bútornáhhoz.

SK

Naše priamy servis pre časti kovania  
Ak by Vám chýbala nejaká časť kovania, môžete poslať túto servisnú  
kártyu poslať faxom priamo na nižšie uvedené faxové číslo. Diely  
kovania vieme poslať iba týmto spôsobom. Ak by ste mali inú  
reklamáciu ohľadom Vašho nábytku, obráťte sa priamo na Vašu  
predajnú nábytku.

SLO

Naše direktno služne storitve za okovje  
Če vam manjka kakšno okovje, lahko to servisno kartico pošljete po  
faksu direktno na spodnjo številko. Po tej poti vam lahko pošljemo  
samo okovje. Če želite reklamirati kakšen drug del pohištva, se obrnite  
neposredno na vašo trgovino pohitva.

RO

Service-ul nostru direct pentru feronerie  
In cazul in care va lipseste o piesa de feronerie puteti sa trimitezi  
direct acest card de service pe fax la numarul de mai jos. Noi nu  
putem expedia piese de feronerie decat pe acestul cale. Decat avegi o  
alta reclamatie referitoare la piesa de mobilier, atunci va rugam sa va  
adresati direct la magazinul dvs. de mobilă.

RUS

Наш прямой сервис для поставок фурнитуры  
Если окажется, что Вам не хватает того или иного элемента  
фурнитуры, Вы можете отправить сервисную карту по Факсу  
непосредственно на нижеприведенный номер. Однако, таким  
образом мы можем пересылать лишь фурнитуру. Если же у Вас  
возникнут иные претензии относительно приобретенной мебели,  
пожалуйста, обращайтесь непосредственно в организацию,  
осуществляющую продажу.

S

Vår direktservice för beslagdelar  
Om du saknar en beslagdel kan du faxa detta servicekort direkt till  
numret som anges ned. Tänk på att detta är den enda möjligheten att  
skicka beslagdelar till dig. Om du vill reklamera din möbel av en  
annan anledning måste du kontakta ditt möbelhus direkt.

ES

Nuestro servicio directo para accesorios  
Si le falta algún accesorio, puede enviar esta tarjeta de servicio  
directamente a la siguiente dirección. No obstante, por este método  
solo podemos enviar accesorios. Si tiene alguna otra objeción sobre su  
mueble, consulte directamente con su mueblería.

TR

Detaylı bir doğrudan servisi  
Bir donatınız eksikse bu servis kartını doğrudan aşağıda bulunan  
adrese doğrudan mail yazabilirsiniz. Sadece bu yolla donatıları  
gönderebilirsiniz. Mobilyanızda başka şikayetleriniz varsa lütfen doğrudan  
mobilya satıcınıza danışın.

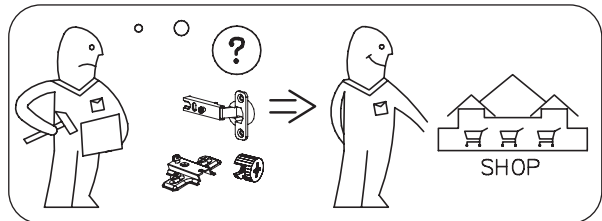
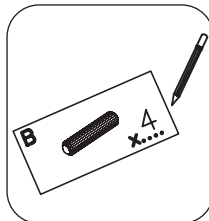
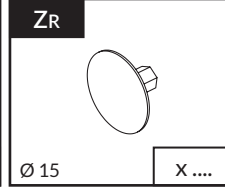
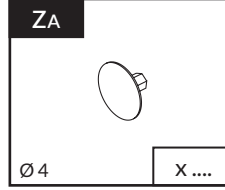
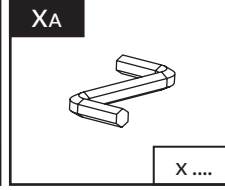
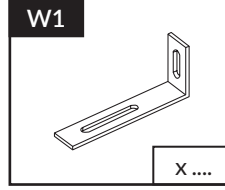
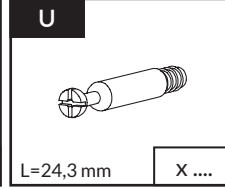
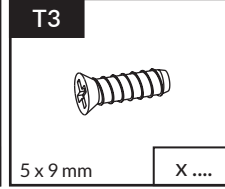
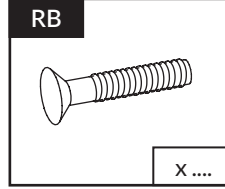
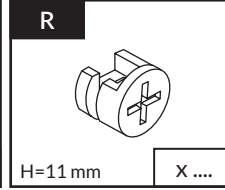
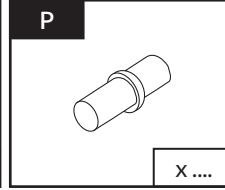
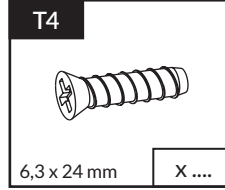
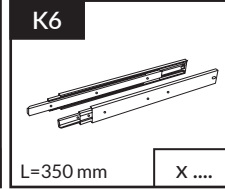
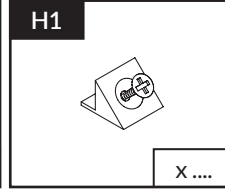
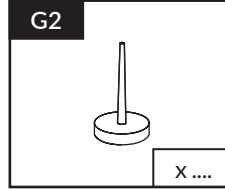
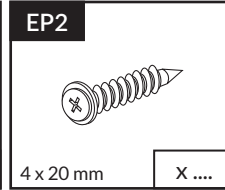
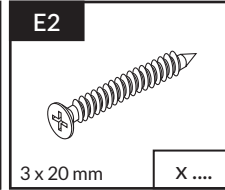
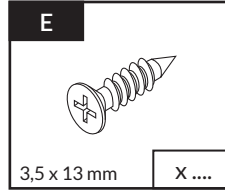
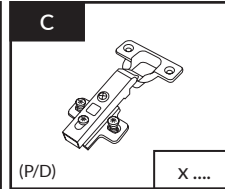
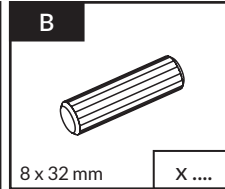
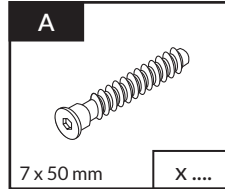

Name • Nom • Nome • Naam • Nazwa • Иméно  
• Názov • Név • Denumire • Isim • Извание

Nr • No • N° • Номер • Č • Sz

Typ • Type • Tip • Típus • Tipo • Tun

GARDEN

--

1D4S/138

D

Unser Direktservice für Beschlagteile  
Sollte Ihnen ein Beschlagteil fehlen, können Sie diese Servicekarte  
direct an die untenstehende Nummer senden. Wir können allerdings  
nur Beschlagteile auf diesem Weg verschicken. Sollen Sie eine andere  
Beanstandung an Ihrem Möbelstück haben, so wenden Sie sich bitte  
direkt an Ihr Möbelhaus.

GB

Our direct order service for fitting  
If a fitting should be missing to you, you know this service map  
directly following number faxes. We can in this way send away  
however only fitting. If you should have another objection to your  
piece of furniture, then they turn please to your furniture house.

CZ

Naše přímé služby pro kování  
Chybí-li vám nějaký díl z kování, můžete tuto servisní kartu odfaxovat  
přímo na níže uvedené číslo. Touto cestou však můžeme zoslat jen  
díly kování. Pokud byste reklamovali jiný díl nábytku, obraťte se přímo  
na svého prodejce nábytku.

F

Bien étudier la notice de montage  
Repérez les pièces constituant votre meuble. Regroupez et contrôlez la  
quincaillerie. Munissez - vous de l'outillage nécessaire. Aménagez -  
vous une zone de montage. Procédez au montage. Ne jamais forcer  
les assemblages. Resserrez les vis après quelques temps d'usage.  
Garder votre notice de montage, si une pièce venait à manquer, elle  
serait le plus clair moyen de communiquer avec votre magasin.

I

Il nostro servizio diretto per l'ordine della ferramenta  
Nel caso vi mancassero dei pezzi, potete spedire fax questa carta di  
servizi direttamente al seguente numero. Per altri reclami al vostro  
mobile, potete rivolgervi al vostro mobilificio.

BG

Директно обслужаване на електрични "Обзор"  
Ако ви недостига някаква част за монтаж, можете да изпратите тази  
сервисна карта директно на посочения номер по факс. Можем да ви  
послат само частите за монтаж. Ако имате друга претензия към  
мобилния ви комплект, моля да се обърнете директно към  
продавача на мебелта.

NL

Onze directservice voor losse onderdelen  
Wanneer er een onderdeel mist kunt u deze servicekaart direct aan  
onderstaand faxnummer sturen. Wij kunnen alleen langs deze weg  
onderdelen versturen. Mocht u een ander probleem aan uw meubel  
hebben verzeken wij u contact op te nemen met uw meubeldealer.

PL

Nasz bezpośredni serwis części montażowych  
Jeżeli brakuje części koniecznych do montażu, prosimy o przesłanie  
nam tej karty serwisowej na niżej podany numer faxu. Możemy w ten  
sposób przysłać państwu tylko brakujące części. W przypadku innych  
objawów dotyczących mebla, prosimy o zgłoszenie ich do salonu  
meblowego w którym został dokonany zakup.

HR

Servis za okove  
U slučaju da nedostaje neki od dijelova molimo vas da na dolje  
navedeni Fax broj posaljete ovaj servisni obrazac. Na ovaj način mogu  
se dostaviti samo okovi. U slučaju da imate dodatne prigovore vezane  
uz komad namještaja molimo vas da se obratite izravno trgovini  
namještaja gdje je isti kupljen.

HU

Direktcsomagátvétel vasalatók esetén  
Ha hiányzik egy vasalató, ezt a kártyát közvetlenül elfaxolhatja az alább  
található faxszámra. Azonban csak a vasalatókat tudunk így küldeni.  
Amennyiben másféle reklamáció áll fenn bútorarabjait illetően,  
forduljon közvetlenül a bútorházzal.

SK

Naše priamy servis pre časti kovania  
Ak by Vám chýbala nejaká časť kovania, môžete poslať túto servisnú  
kártyu poslať faxom priamo na nižšie uvedené číslo. Dielu  
kovania vieme poslať iba týmto spôsobom. Ak by ste mali inú  
reklamáciu ohľadom Vašho nábytku, obraťte sa priamo na Vašu  
predajnú nábytku.

SLO

Naše direktno služne storitve za okovje  
Če vam manjka kakšno okovje, lahko to servisno kartico pošljete po  
faksu direktno na spodnjo številko. Po tej poti vam lahko pošljemo  
samo okovje. Če želite reklamirati kakšen drug del pohištva, se obrnite  
neposredno na vašo trgovino pohištva.

RO

Service-ul nostru direct pentru feronerie  
În cazul în care vă lipsesc o piesă de feronerie puteți să trimiteți  
direct acest card de service pe fax la numărul de mai jos. Noi nu  
putem expedia piese de feronerie decât pe această cale. Dacă aveți o  
altă reclamație referitoare la piese de mobilier, atunci vă rugăm să vă  
adresați direct la magazinul dvs. de mobilă.

RUS

Наш прямой сервис для поставок фурнитуры  
Если окажется, что Вам не хватает того или иного элемента  
фурнитуры, Вы можете отправить сервисную карту по Факсу  
непосредственно на нижеприведенный номер. Однако, таким  
образом мы можем пересылать лишь фурнитуру. Если же у Вас  
возникнут иные претензии относительно приобретенной мебели,  
пожалуйста, обращайтесь непосредственно в организацию,  
осуществляющую продажу.

S

Vår direktservice för beslagdelar  
Om du saknar en beslagdel kan du faxa detta servicekort direkt till  
numret som anges ned. Tänk på att detta är den enda möjligheten att  
skicka beslagdelar till dig. Om du vill reklamera din möbel av en  
annan anledning måste du kontakta ditt möbelhus direkt.

ES

Nuestro servicio directo para accesorios  
Si le falta algún accesorio, puede enviar esta tarjeta de servicio  
directamente a la siguiente dirección. No obstante, por este método  
solo podemos enviar accesorios. Si tiene alguna otra objeción sobre su  
mueble, consulte directamente con su mueblería.

TR

Donatılar için doğrudan servisimiz  
Bir donatınız eksikse bu servis kartını doğrudan aşağıda bulunan  
adrese doğrudan mail yazabilirsiniz. Sadece bu yolla donatılar  
gönderebiliriz. Mobilyanızda başka şikayetleriniz varsa lütfen doğrudan  
mobilya satıcınıza danışın.

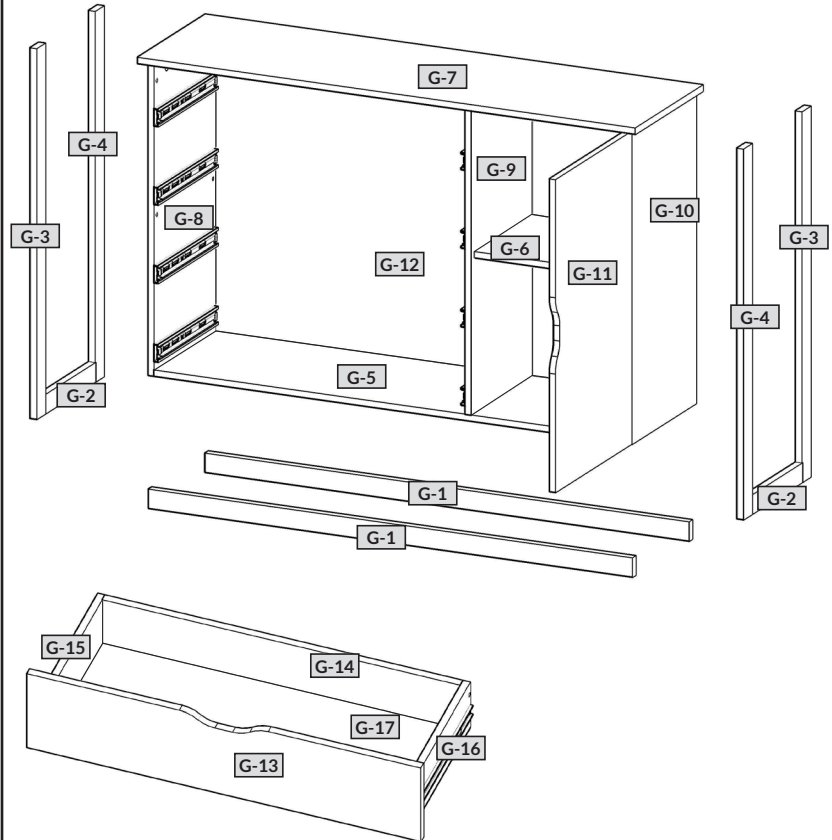

| nr   | ↔ [mm] | ↓ [mm] | ∅ [mm] | Menge | Colli |
|------|--------|--------|--------|-------|-------|
| G-1  | 1340   | 50     | 15     | x 2   | 1/2   |
| G-2  | 294    | 50     | 15     | x 2   | 1/2   |
| G-3  | 972    | 50     | 15     | x 2   | 2/2   |
| G-4  | 972    | 50     | 15     | x 2   | 2/2   |
| G-5  | 1308   | 359    | 16     | x 1   | 1/2   |
| G-6  | 430    | 340    | 16     | x 1   | 1/2   |
| G-7  | 1378   | 396    | 16     | x 1   | 1/2   |
| G-8  | 822    | 374    | 16     | x 1   | 2/2   |
| G-9  | 806    | 359    | 16     | x 1   | 2/2   |
| G-10 | 822    | 374    | 16     | x 1   | 2/2   |
| G-11 | 446    | 820    | 16     | x 1   | 2/2   |
| G-12 | 1322   | 830    | 3      | x 1   | 1/2   |
| G-13 | 886    | 202    | 16     | x 4   | 1/2   |
| G-14 | 806    | 120    | 16     | x 4   | 1/2   |
| G-15 | 350    | 120    | 16     | x 4   | 1/2   |
| G-16 | 350    | 120    | 16     | x 4   | 1/2   |
| G-17 | 838    | 357    | 3      | x 4   | 2/2   |

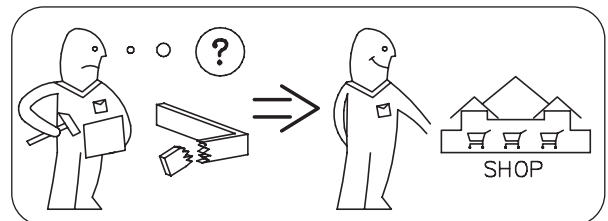







|                        |   |
|------------------------|---|
| <b><span>DE</span></b> | Möbel aus Naturholz und Plattenwerkstoffen            |
| <b><span>PL</span></b> | Mebel z drewna naturalnego oraz płyt drewnopochodnych |
| <b><span>NL</span></b> | Meubelen van natuurhout en plaatmateriaal             |
| <b><span>GB</span></b> | Furniture made of natural wood and panel materials    |
| <b><span>IT</span></b> | Mobili in legno naturale e materiali pannellati       |
| <b><span>FR</span></b> | Meuble en bois naturel et plaque en dérivé du bois    |

## DE

**Liebe Kundin,**
**lieber Kunde,**
wir dank Ihnen Bestelung!
Gleichzeitig ob Sie ein aus Naturholz gefertigtes Möbelstück gekauft haben, eine Hochglanzfront oder eine matte Kunststofffront – jedes Möbelstück hat seine ganz speziellen Eigenschaften. Auch Holzbeschaffenheit und -struktur, wie zum Beispiel die rone Aste bei Naturholzmeublen, sind Teil der individuellen Ausgestaltung jedes einzelnen Möbelstücks.

Da Möbel aus Naturholz ständigen Klima- und Feuchtigkeitsschwankungen ausgesetzt sind, können vereinzelt Veränderungen in der Oberfläche auftreten, wie z.B. Haarrisse oder Farbveränderungen. Generell nimmt im Laufe der Zeit die Helligkeit ab und die Farbsättigung zu – das Holz dunkelt nach.

Die meisten Natur-Rohstoffe wie Holz ein normaler Prozess. Dieses Buchlein soll Ihnen ein paar Tipps zur Pflege Ihres Möbelstücks geben, damit Sie lange Freude daran haben können.

### Grundätzlich gilt:

Möbeln sind Gegenstände auf die wir jeden Tag einwirken, sie sind bei einer Natur-Rohstoff wie Holz ein normaler Prozess. Dieses Buchlein soll Ihnen ein paar Tipps zur Pflege Ihres Möbelstücks geben, damit Sie lange Freude daran haben können.

**Grundätzlich gilt:**
Möbeln sind Gegenstände auf die wir jeden Tag einwirken, sie sind bei einer Natur-Rohstoff wie Holz ein normaler Prozess. Dieses Buchlein soll Ihnen ein paar Tipps zur Pflege Ihres Möbelstücks geben, damit Sie lange Freude daran haben können.

**Grundätzlich gilt:**
Möbeln sind Gegenstände auf die wir jeden Tag einwirken, sie sind bei einer Natur-Rohstoff wie Holz ein normaler Prozess. Dieses Buchlein soll Ihnen ein paar Tipps zur Pflege Ihres Möbelstücks geben, damit Sie lange Freude daran haben können.

**Grundätzlich gilt:**
Möbeln sind Gegenstände auf die wir jeden Tag einwirken, sie sind bei einer Natur-Rohstoff wie Holz ein normaler Prozess. Dieses Buchlein soll Ihnen ein paar Tipps zur Pflege Ihres Möbelstücks geben, damit Sie lange Freude daran haben können.

**Grundätzlich gilt:**
Möbeln sind Gegenstände auf die wir jeden Tag einwirken, sie sind bei einer Natur-Rohstoff wie Holz ein normaler Prozess. Dieses Buchlein soll Ihnen ein paar Tipps zur Pflege Ihres Möbelstücks geben, damit Sie lange Freude daran haben können.

**Grundätzlich gilt:**
Möbeln sind Gegenstände auf die wir jeden Tag einwirken, sie sind bei einer Natur-Rohstoff wie Holz ein normaler Prozess. Dieses Buchlein soll Ihnen ein paar Tipps zur Pflege Ihres Möbelstücks geben, damit Sie lange Freude daran haben können.

**Grundätzlich gilt:**
Möbeln sind Gegenstände auf die wir jeden Tag einwirken, sie sind bei einer Natur-Rohstoff wie Holz ein normaler Prozess. Dieses Buchlein soll Ihnen ein paar Tipps zur Pflege Ihres Möbelstücks geben, damit Sie lange Freude daran haben können.

**Grundätzlich gilt:**
Möbeln sind Gegenstände auf die wir jeden Tag einwirken, sie sind bei einer Natur-Rohstoff wie Holz ein normaler Prozess. Dieses Buchlein soll Ihnen ein paar Tipps zur Pflege Ihres Möbelstücks geben, damit Sie lange Freude daran haben können.

**Grundätzlich gilt:**
Möbeln sind Gegenstände auf die wir jeden Tag einwirken, sie sind bei einer Natur-Rohstoff wie Holz ein normaler Prozess. Dieses Buchlein soll Ihnen ein paar Tipps zur Pflege Ihres Möbelstücks geben, damit Sie lange Freude daran haben können.

## Ihre Produktentwicklung

### TR

### RU

### RO

### CZ

### SK

### HU

### PL

### NL

### GB

### IT

### FR

### TR

### RU

### RO

### CZ

### SK

### HU

### PL

### NL

### GB

### IT

### FR

### DE

### Dear customer,

Thank you for your order!
No matter if you bought a piece of furniture made from natural wood, a high-gloss front or a plastic front – every piece of furniture has unique characteristics. Even the texture and structure of wood, such as small knots in natural wood furniture, are part of the individual charisma of each piece of furniture.

Since natural wood furniture are permanently exposed to climate and humidity fluctuations, changes to the surface may occur (e.g. hair cracks or changes in colour) in some cases. In general, brightness decreases and colour saturation increases in the course of time – the wood darkens.

The changes mentioned above are normal for natural raw materials such as wood. This booklet provides some care tips for your piece of furniture so that you can enjoy it for a long time.

**The following applies in general:**
• Don't place any hot objects on the furniture.
• Don't place candles directly on the furniture.

**Immediately wipe off any spilled liquids.**
• Regularly check if the screws and fittings are tight.
• The typical, aromatic wooden odour is always a proof of quality for natural wood furniture.

**The natural emission of resin may produce bright spots on the knots which can be polished with a dry, lintfree cloth.**

**Initially, a slight intrinsic odour is unavoidable for other wooden, paint, leather or upholstery materials too. These odours automatically disappear after a while. If you want to speed up this process, ventilate more often at the beginning and/or wipe out the furniture with a slightly damp cloth which was soaked in water mixed with a small amount of vinegar.**

**Keep these notes in a safe place. Care notes for furniture made of panel materials**

We recommend using a soft, lint-free cloth or a shammy for conditioning your piece of furniture made of panel materials. Wipe off the surfaces with a slightly damp cloth or shammy.

**The following applies in general:**
Please don't use the following detergents or cleaning agents at all:
• **microfibre cloths or dirt erasers.** They often contain fine abrasive particles which can cause scratches on the surfaces;
• **aggressive chemical substances or solvents.** They may damage the surface;
• **scouring powder, steel wool or scouring pads.** They destroy the surface so badly that reconditioning is impossible;
• **vacuum cleaners.** The nozzles and brushes can cause scratches on the surfaces;
• **steam cleaners.** The surfaces may be damaged or separated from the ground due to the high pressure and heat of the water vapour.

## Your product development team

### IT

### Genitori clienti,

sentiti ringraziamenti per il vostro ordine!
A prescindere che abbiate scelto un mobile realizzato in legno naturale, un fronte lucido o un fronte di materiale plastico opaco – ogni esemplare ha sue particolarità. Anche le caratteristiche e la struttura del legno, quali ad esempio rami minori nei mobili di legno naturale, sono parte del fascino individuale di ogni singolo mobile.

Dato che i mobili in legno naturale sono esposti al continuo variare del clima e dell'umidità, è probabile che in superficie insorgano mutamenti quali crepe capillari o cambiamenti di colore. Generalmente con passar del tempo, diminuisce la chiarezza e aumenta la saturazione del colore – il legno si scurisce. I citati mutamenti sono un normale processo dei materiali naturali, quali appunto il legno.

Il presente libretto intende darvi alcuni suggerimenti sulla cura del vostro mobile, affinché vi procuri lunghe soddisfazioni.

### Sostanzialmente vale:

• Non poggiare oggetti roventi sui mobili dei mobili.
• Asciugare subito i liquidi sversati.
• Ad intervalli periodici controllare se vit e cerriente sono salde.
• Il caratteristico odore fragrante è sempre una prova di qualità dei mobili in legno naturale.

**Le macchie chiare sui rami si formano per via della naturale fuoriuscita di resina, e sono levigabili con un panno asciutto che non lascia peli. Anche trattandosi di altri materiali lignei, di vernice, pelle o imbottiti, all'inizio è inevitabile un leggero odore caratteristico. Dopo qualche tempo però, questi odori svaniscono da sé. Potete aiutare a farli volatilizzare in minor tempo cambiando più spesso aria all'inizio e/o passando sui mobili un panno umido d'acqua con qualche goccia d'aceto.**

**Conservare bene le presenti istruzioni. pannellati**
Per la cura dei mobili in materiali pannellati si consiglia di usare un panno morbido, che non lascia peli, o un panno di pelle. Passare il panno leggermente umido sulle superfici.
**Sostanzialmente vale: In nessun caso** utilizzare i seguenti detergenti e prodotti per la pulizia:
• **panni in microfibra o spugne a tampono.** Questi prodotti contengono spesso fini particelle abrasive, che possono provocare sgraffiature sui mobili;
• **forti sostanze chimiche nonché detersivi o solventi abrasivi.** Anche questi prodotti possono aggredire le superfici;
• **polvere abrasiva, paglietta d'acciaio o spugne abrasive.** Rovineranno la superficie in modo tale che non sarebbe più possibile riparare;
• **aspirapolvere.** Bocchette e spazzole possono sgraffiare le superfici;
• **pulitrice a vapore.** Per via dell'elevata pressione e calore con cui il vapore colpisce le superfici, esse rischiano di deteriorarsi o addirittura staccarsi dalla sottostruttura.

## Area Sviluppo prodotti

### FR

**Chère cliente,**
**Cher client,**
merci pour votre commande !
Peu importe que vous ayez acheté un meuble fabriqué en bois naturel, un face haute brillance ou une face en plastique mat – chaque meuble a ses propriétés spécifiques. Même les propriétés et la structure du bois, comme par exemple les petits nœuds sur des meubles en bois naturel, font partie de l'aspect de chaque meuble.

Comme les variations permanentes du climat et de l'humidité, il se peut que quelques modifications surviennent sur la surface, comme par exemple de fines fissures ou des décorations. En règle générale, au cours du temps, la clarté du meuble diminue et la saturation des couleurs augmente – le bois devient foncé.

Les modifications susnommées sont un processus normal des matières naturelles.

Ce petit livret vous donne quelques astuces sur l'entretien de votre meuble pour que vous puissiez en profiter longtemps.

**En règle générale :**

• Ne pas poser de bougies directement sur le meuble.
• Essayer immédiatement les liquides renversés.

• A intervalles réguliers, compter que les vis et les ferrures sont bien en place.
• Le léger, aromatique parfum des bois est toujours une preuve de qualité des meubles en bois naturel.
• Les endroits clairs sur les nœuds se produisent par une sécrétion naturelle de résine qui s'élimine avec un chiffon sec non pelucheux.

• Les autres matériaux, comme le bois, la peinture, le cuir, peuvent également dégager inévitablement une légère odeur. Ces odeurs disparaissent d'elles-mêmes avec le temps. Si vous souhaitez qu'elles disparaissent plus vite, au début, aérez plus souvent et essayez les meubles avec un chiffon légèrement imbibé d'eau mélangée avec un peu de vinaigre.

**Conservez bien cette notice. Consignes de soin pour les meubles avec des plaques en dérivé du bois**
Pour l'entretien de votre meuble en plaques en dérivé du bois, utilisez de préférence un chiffon doux non pelucheux à l'eau pe de vinasse. Essayez la pelle.
**En règle générale :** Veuillez n'utiliser que des produits doux.
**Chiffons à microfibre ou gomme à saletés.** Ils contiennent souvent de fines particules abrasives qui peuvent rayeur les surfaces;
**substances chimiques agressives ou solvants abrasifs.** Ils peuvent également endommager les surfaces;
**Consignes de soin pour les meubles avec des plaques en dérivé du bois**
Pour l'entretien de votre meuble en plaques en dérivé du bois, utilisez de préférence un chiffon doux non pelucheux à l'eau pe de vinasse. Essayez la pelle.
**En règle générale :** Veuillez n'utiliser que des produits doux.
**Chiffons à microfibre ou gomme à saletés.** Ils contiennent souvent de fines particules abrasives qui peuvent rayeur les surfaces;
**substances chimiques agressives ou solvants abrasifs.** Ils peuvent également endommager les surfaces;

**Votre service de développement de produits**

