

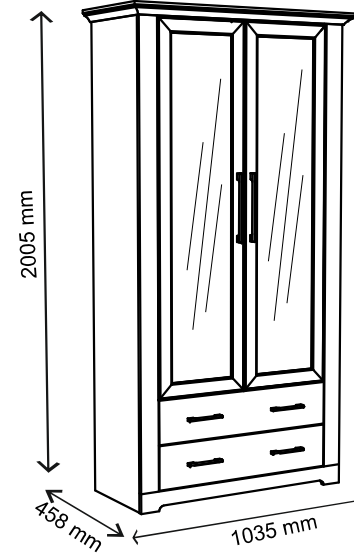

Installation manual

ARSAL: WIT 2W2S

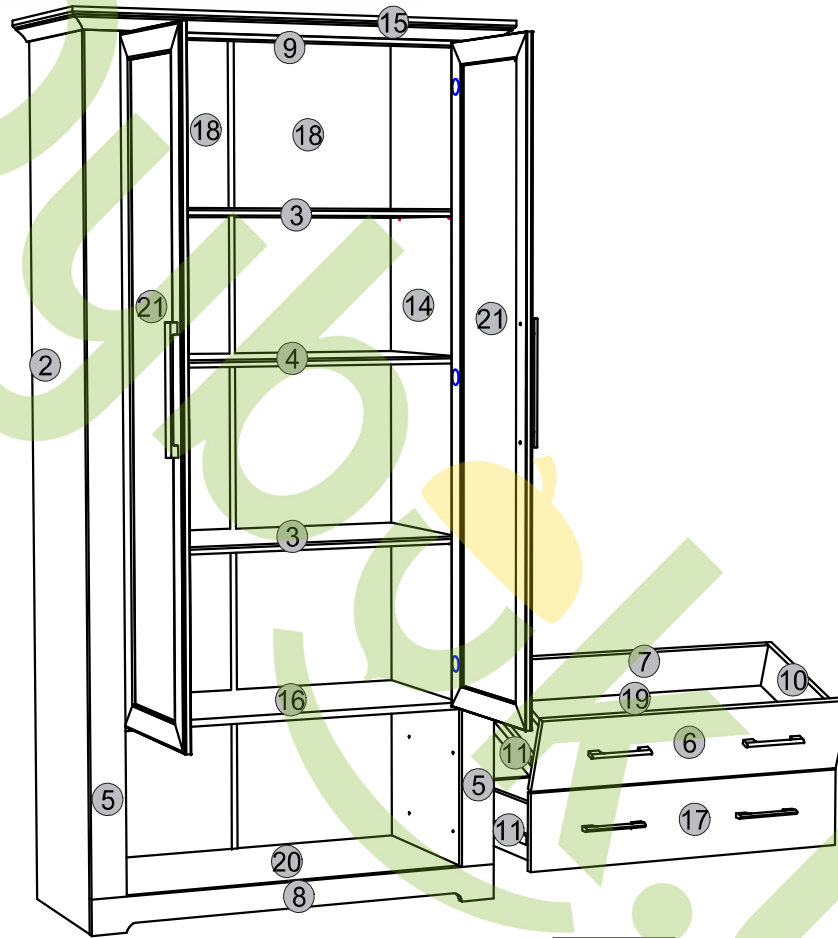
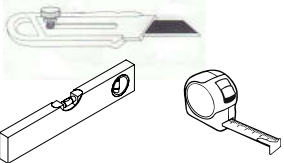
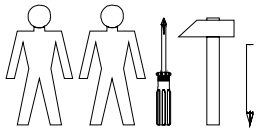

Element symbol	Dimensions				Code	Package
1	1984	404	16	1	WIT_WYS_2W2S.003	2/2
2	1984	404	16	1	WIT_WYS_2W2S.004	2/2
3	803	390	16	2	WIT_WYS_2W2S.006	3/3
4	803	390	16	1	WIT_WYS_2W2S.007	3/3
5	1904	80	16	2	WIT_WYS_2W2S.008	1/1
6	796	180	16	1	WIT_WYS_2W2S.009	3/3
7	745	130	16	2	WIT_WYS_2W2S.010	3/3
8	961	80	16	1	WIT_WYS_2W2S.011	3/3
9	803	60	16	1	WIT_WYS_2W2S.012	3/3
10	350	130	16	2	WIT_WYS_2W2S.013	3/3
11	350	130	16	2	WIT_WYS_2W2S.014	3/3
12	60	334	16	2	WIT_WYS_2W2S.015	3/3
13	1904	401	16	1	WIT_WYS_2W2S.016	1/1
14	1904	401	16	1	WIT_WYS_2W2S.017	1/1
15	1035	458	16	1	WIT_WYS_2W2S.018	3/3
16	803	401	16	1	WIT_WYS_2W2S.019	3/3
17	796	180	16	1	WIT_WYS_2W2S.020	3/3
18	1929	472	3	2	WIT_WYS_2W2S.001	1/1
19	763	352	3	2	WIT_WYS_2W2S.002	2/2
20	927	401	16	1	WIT_WYS_2W2S.005	3/3
21	1502	396	16	2	WIT_WYS_2W2S.W1	4/4

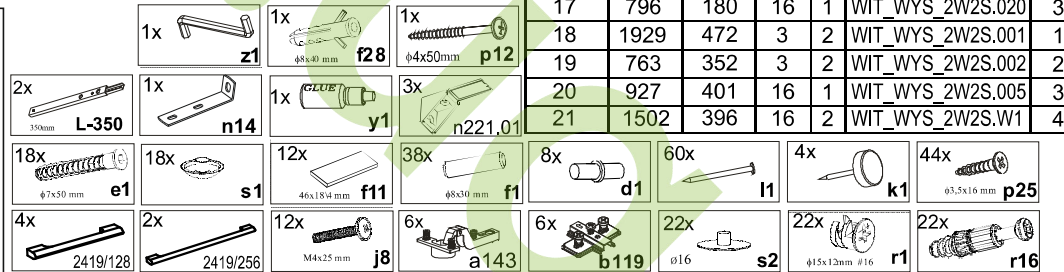
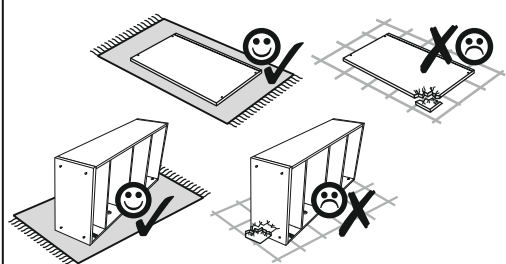
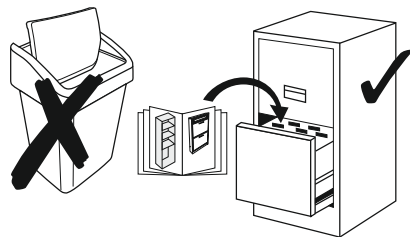

1

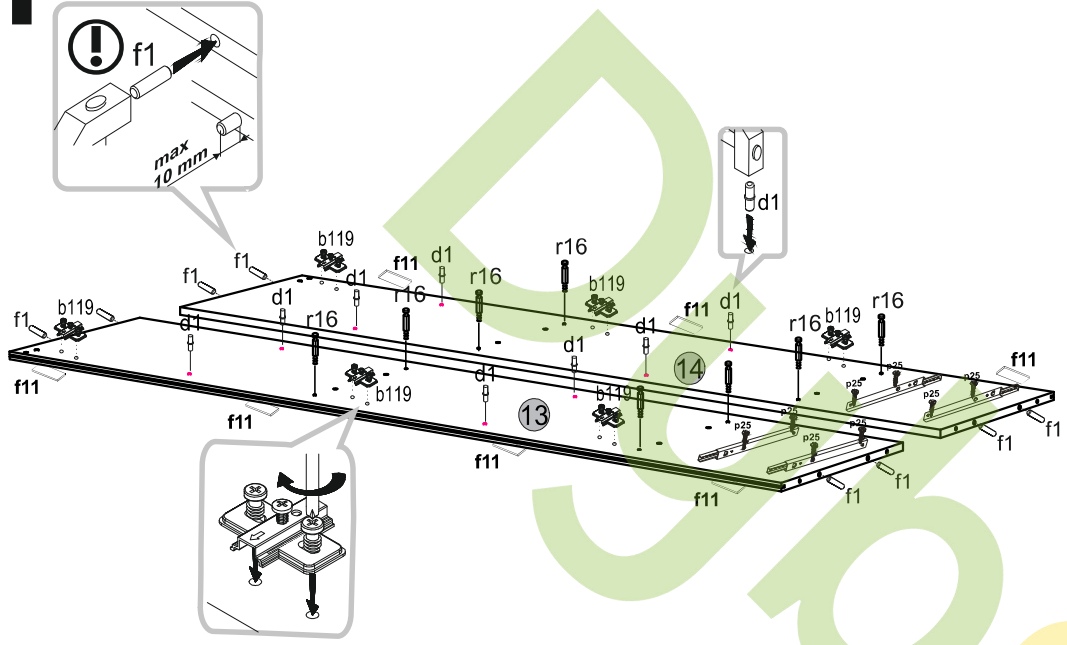

3

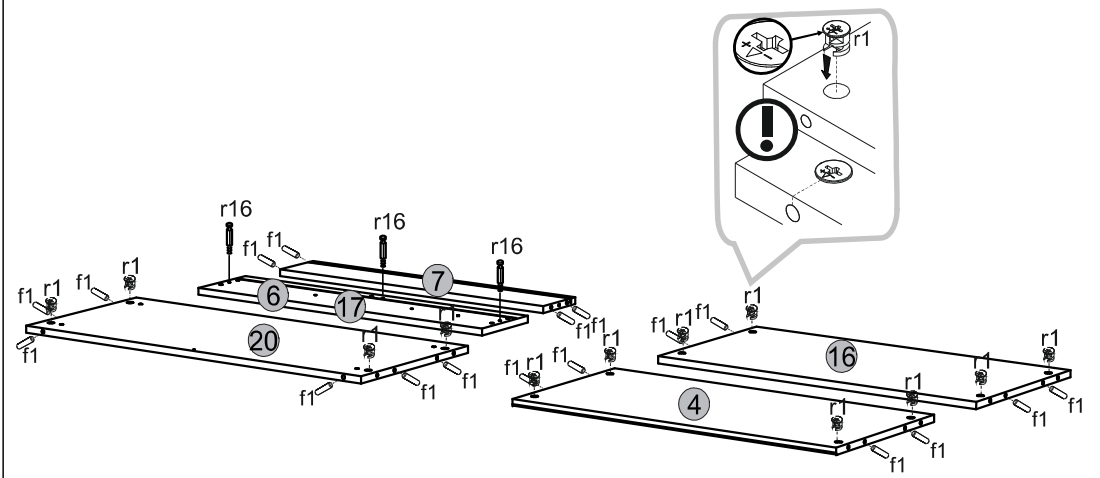

2

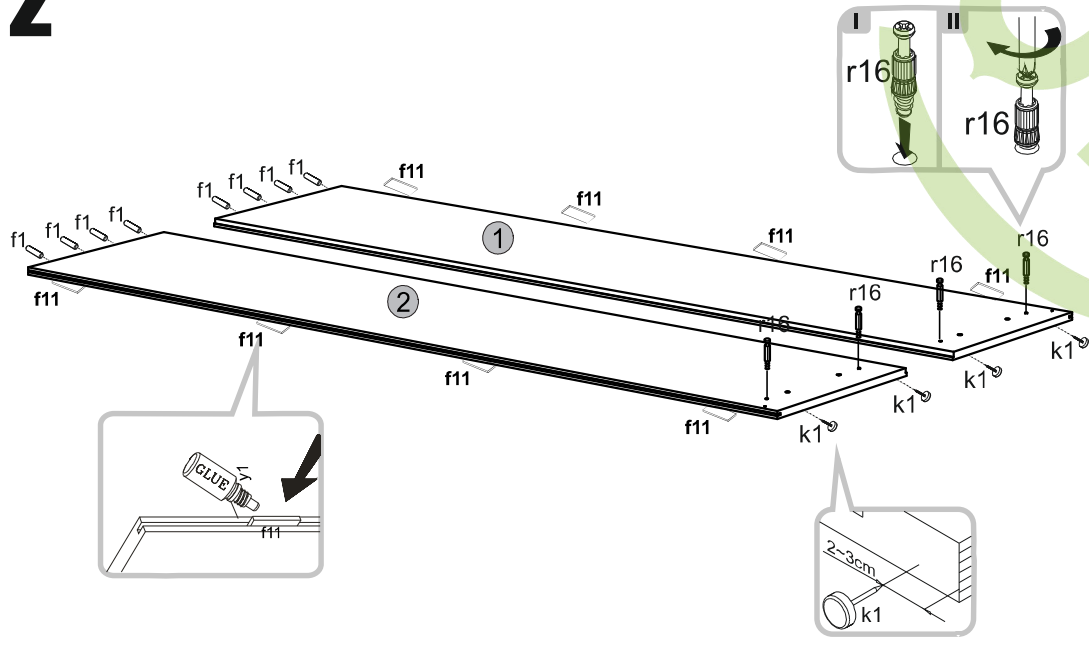

4

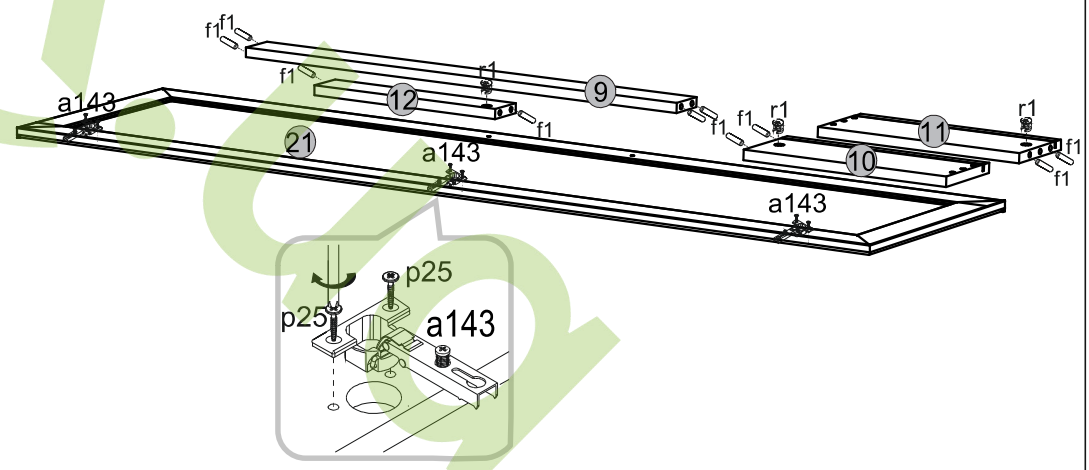

5

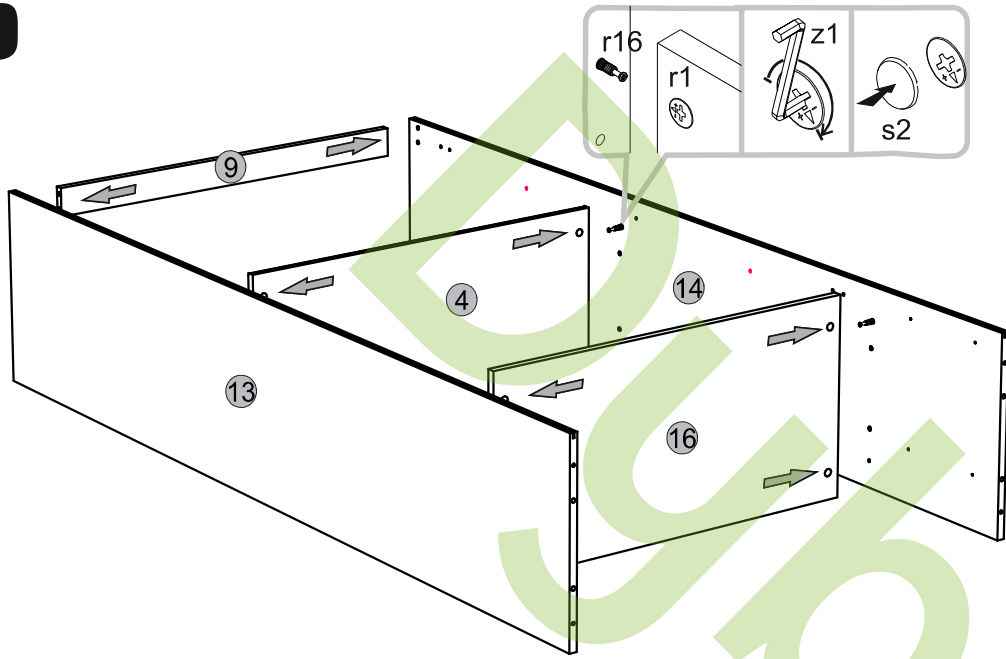

7

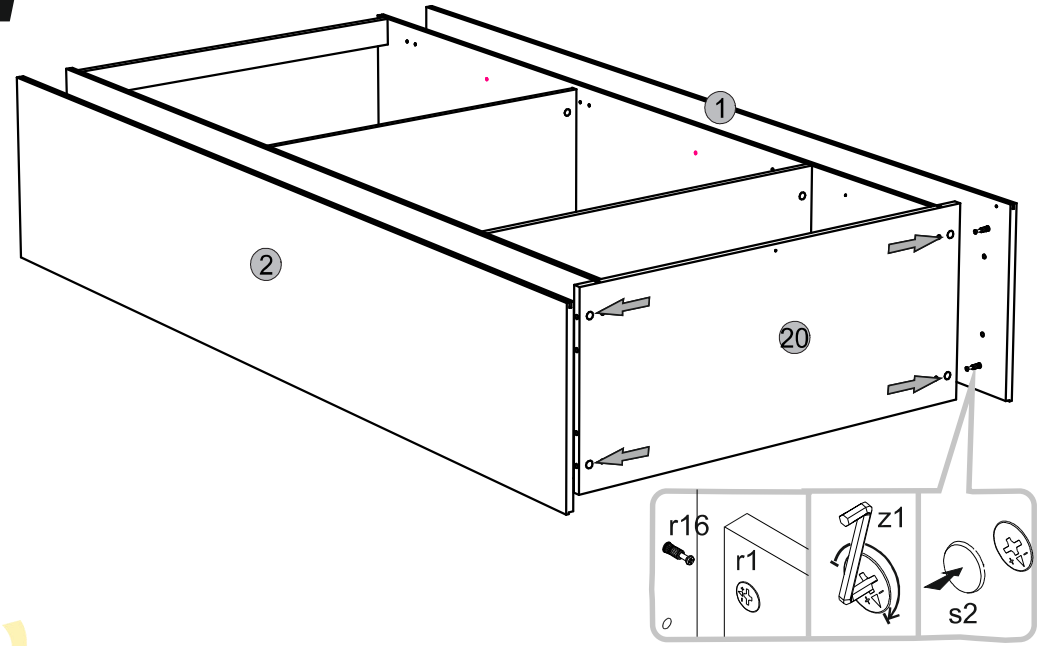

6

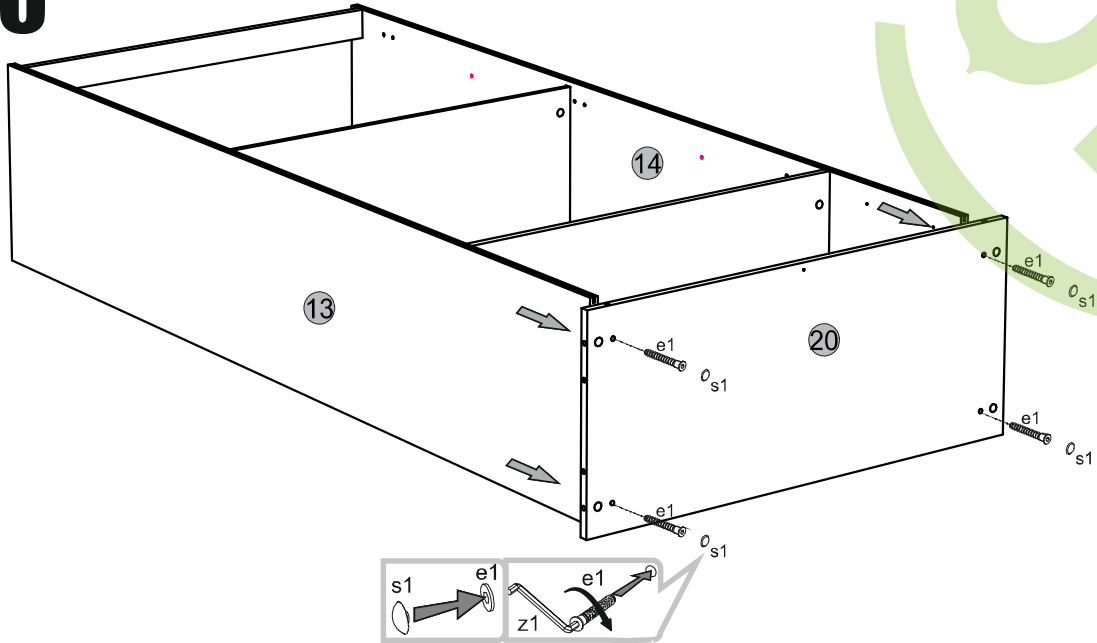

8

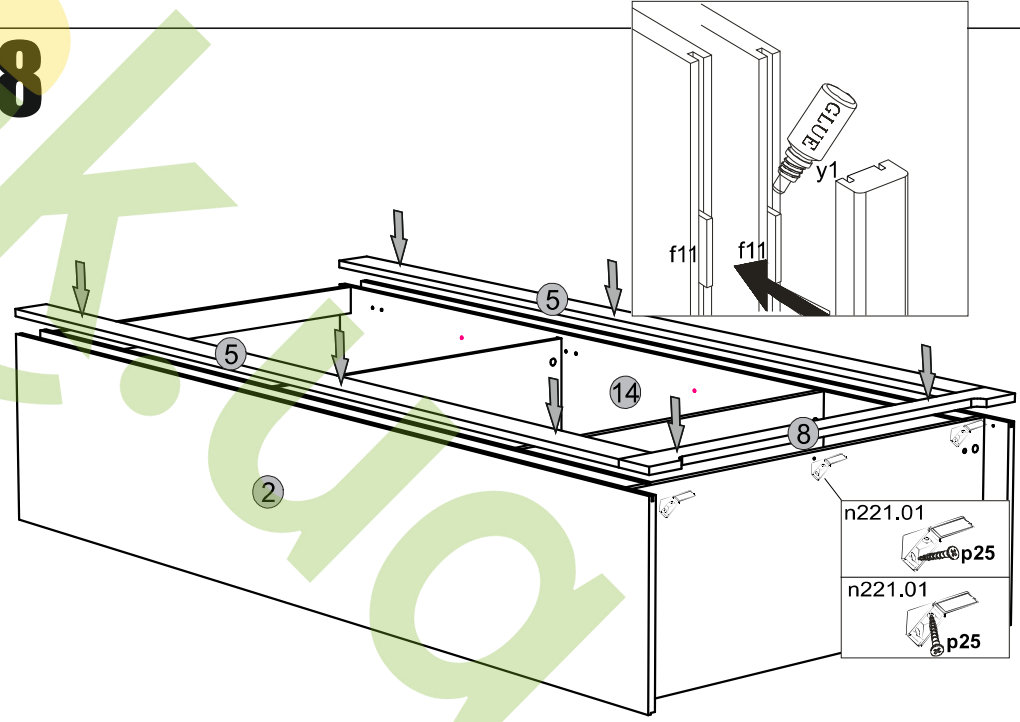

9

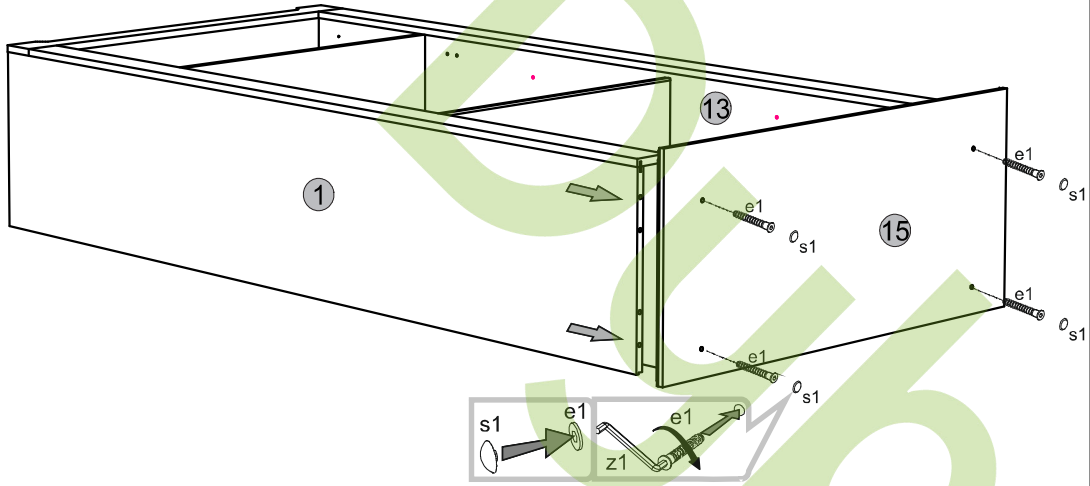

10

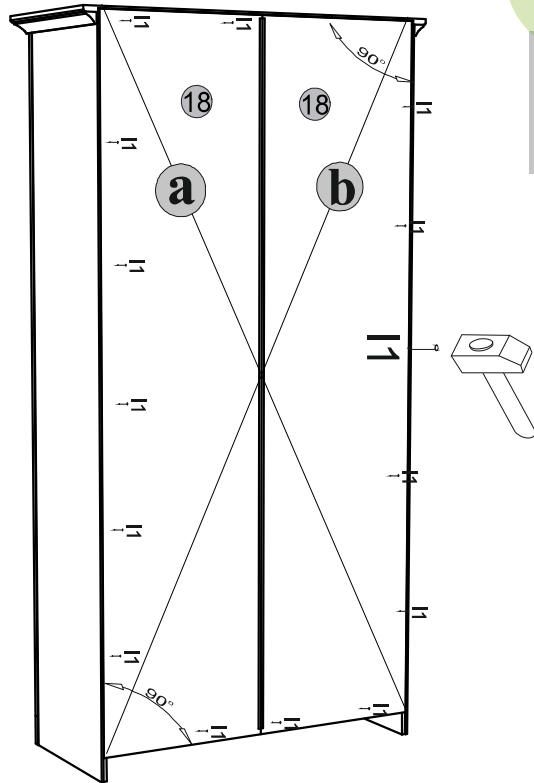

⚠ a=b

11

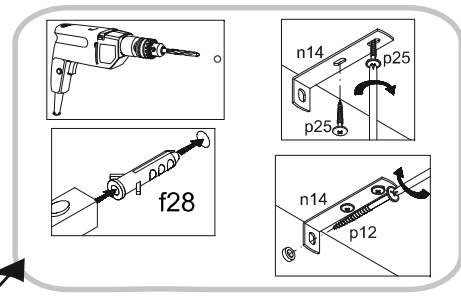

12

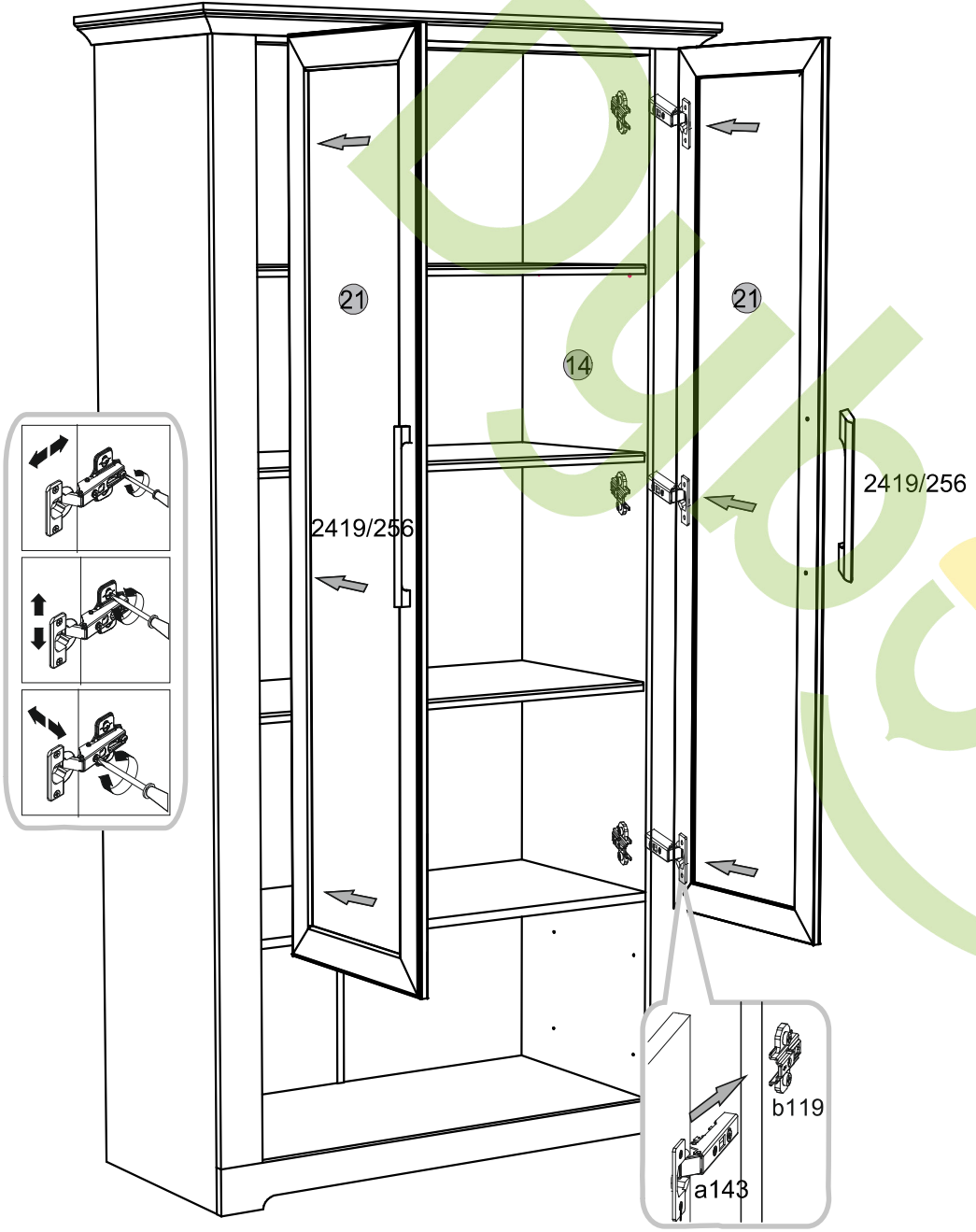

13

