

КОЕН

Тумба для взуття / Тумба для обуви_3D

| A | B | C | | D |
|----|-----------|--------|-----|-----|
| 1 | S136-042 | 338 | 566 | 3/3 |
| 1A | S136-042A | 338 | 566 | 3/3 |
| 2 | S136-190 | 1191 | 150 | 1/3 |
| 3 | S136-191 | 1191 | 150 | 1/3 |
| 4 | S136-192 | 1106,5 | 150 | 1/3 |
| 5 | S136-193 | 1106,5 | 150 | 1/3 |
| 6 | S136-229 | 700 | 150 | 1/3 |
| 7 | S136-347 | 667 | 150 | 1/3 |
| 8 | S136-454 | 667 | 68 | 1/3 |
| 9 | S136-455 | 571 | 50 | 1/3 |
| 10 | S136-457 | 566 | 60 | 1/3 |
| 11 | S136-458 | 572 | 60 | 1/3 |
| 12 | S136-520 | 599 | 140 | 1/3 |
| 13 | S136-522 | 599 | 55 | 1/3 |
| 14 | S136-932 | 1134 | 346 | 1/3 |
| 15 | S136-931 | 1134 | 346 | 1/3 |
| 16 | LH-1106 | 1106 | 14 | 1/3 |
| 17 | S136-562 | 701 | 65 | 2/3 |
| 18 | S136-563 | 1208 | 65 | 2/3 |
| 19 | S136-564 | 1208 | 65 | 2/3 |
| 20 | S136-521 | 599 | 65 | 1/3 |

→ Фасад ДСП
→ Фасад МДФ

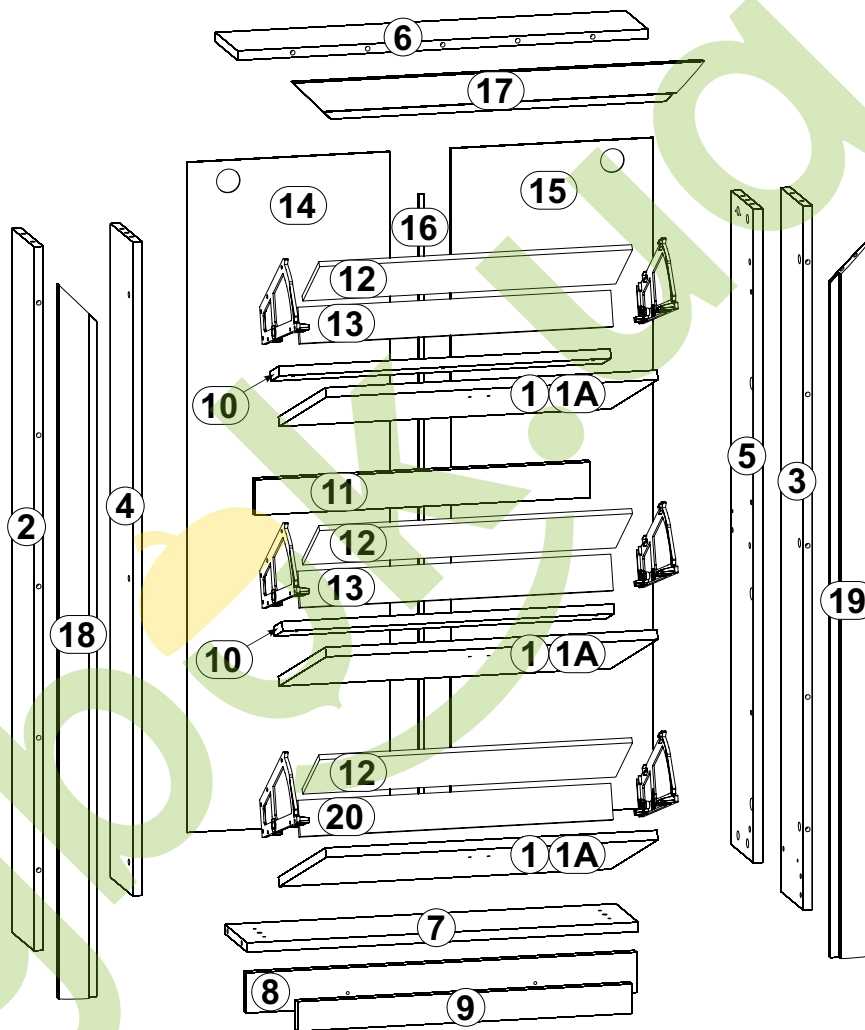
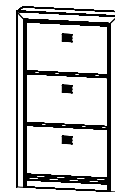
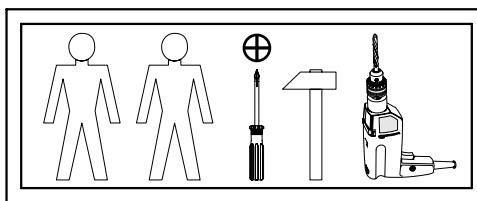

| | | | | | | | |
|--------------------------------|-----------------------------|------------------------------|---------------------------|----------------------------|-----------------------------|------------------------------|-----------------------------|
| 3x c317 | 24x e2 φ6.3x13 mm | 24x f1 Ø8x30 mm | 6x f15 | 2x f35 φ10x50 mm | 6x j30 M4x22 mm | 4x k1 | |
| 45x l1 | 6x m10 | 6x m11 | 6x n2 | 6x n3 | 2x n122/1 | 12x p27 φ3,5x13 mm | |
| 3x m18 ⁻ | 3x m18 ⁺ | 24x p15 Ø2,5x13 mm | 4x p21 Ø4x30 mm | 2x p75 φ6x60 mm | 6x p79 Ø3,5x20 mm | 2x p94 φ4x28 mm | |
| 25x r1 Ø15x12 mm #16 | 2x r10 | 21x r42 20/11 | 6x s2 Ø16 | | | | 12x p100 Ø3x10 mm |

1

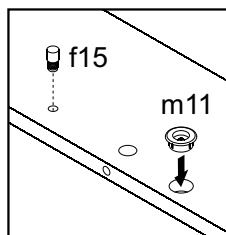
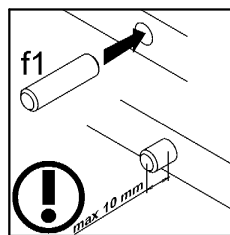
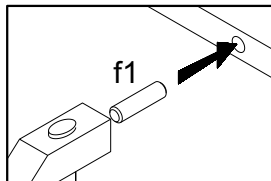
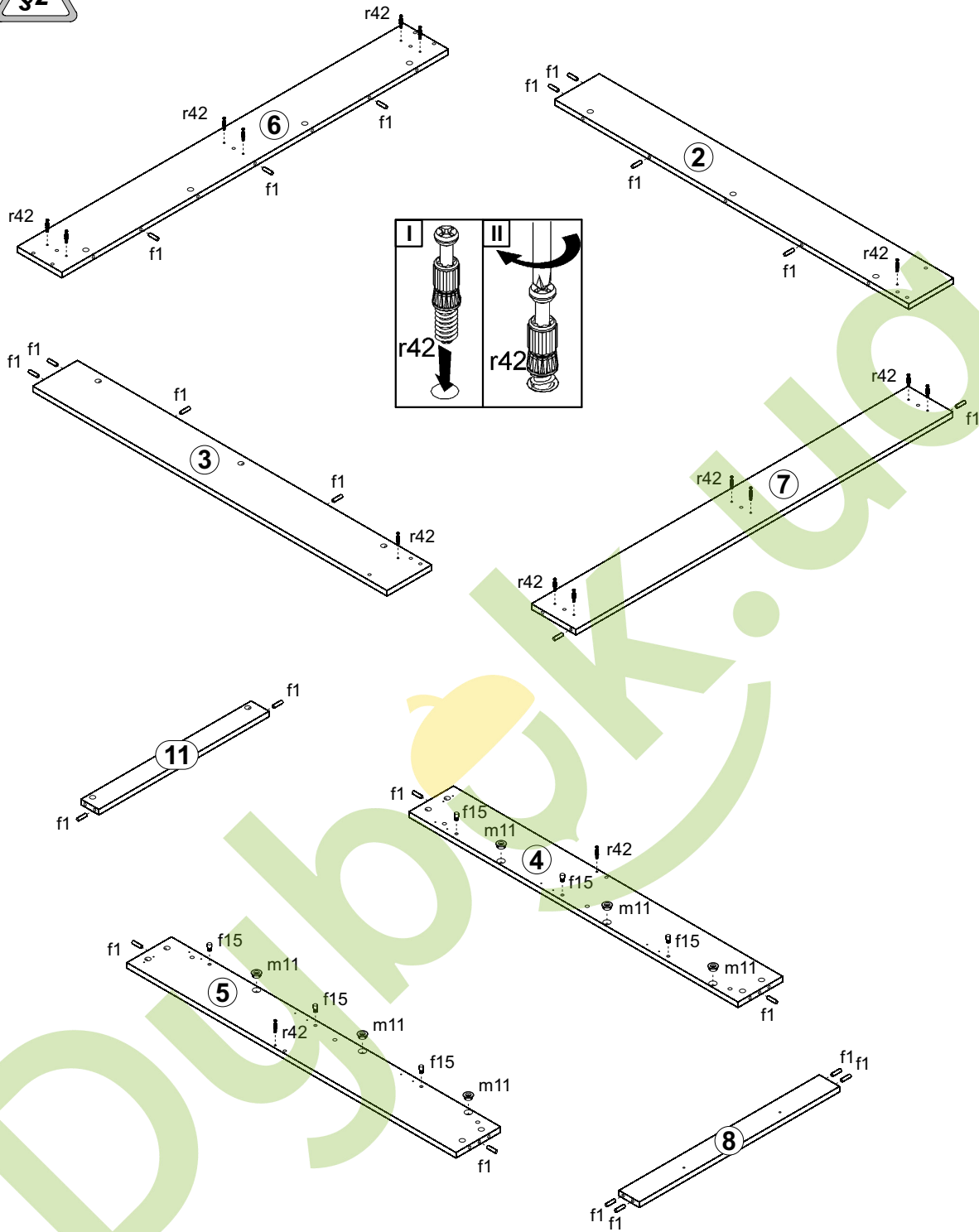

2

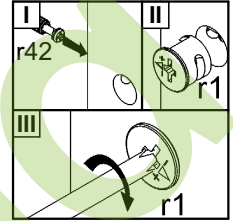
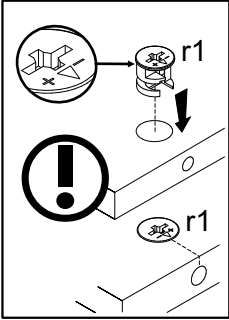
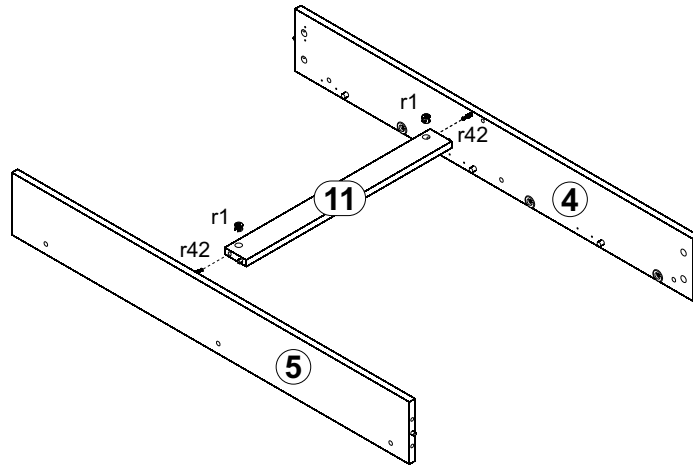

3

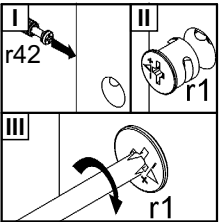
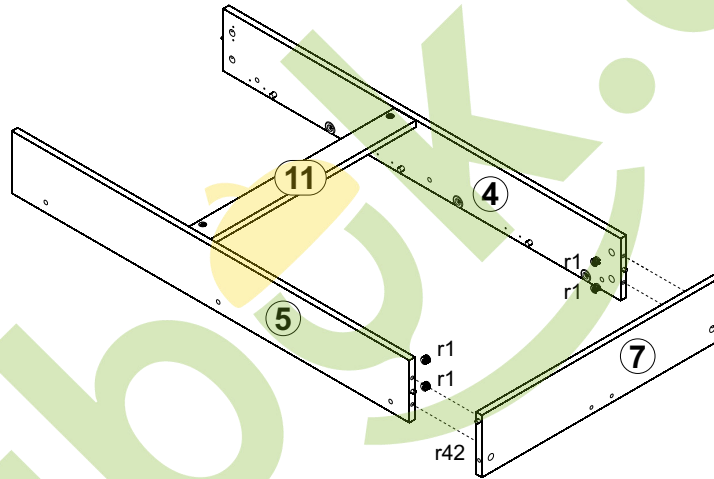

4

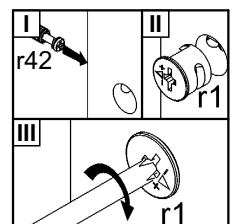
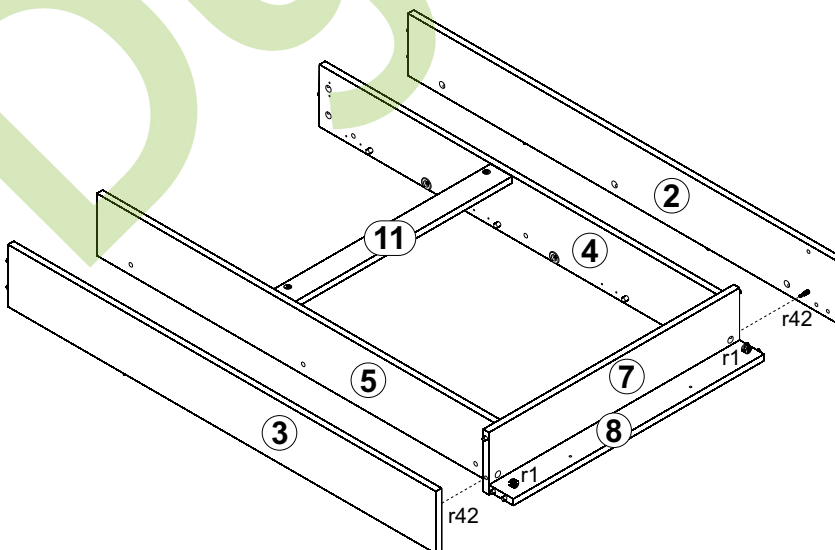

5

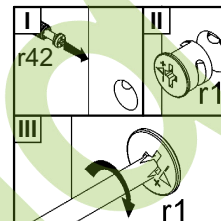
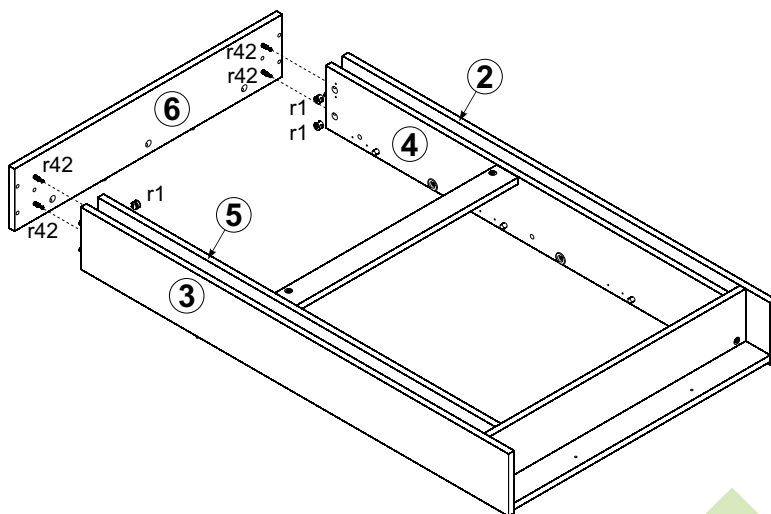

6

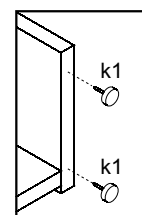
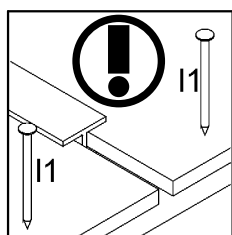
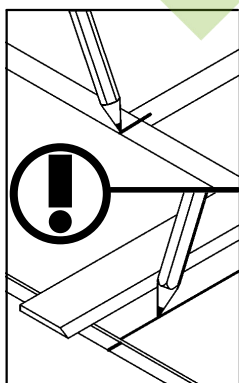
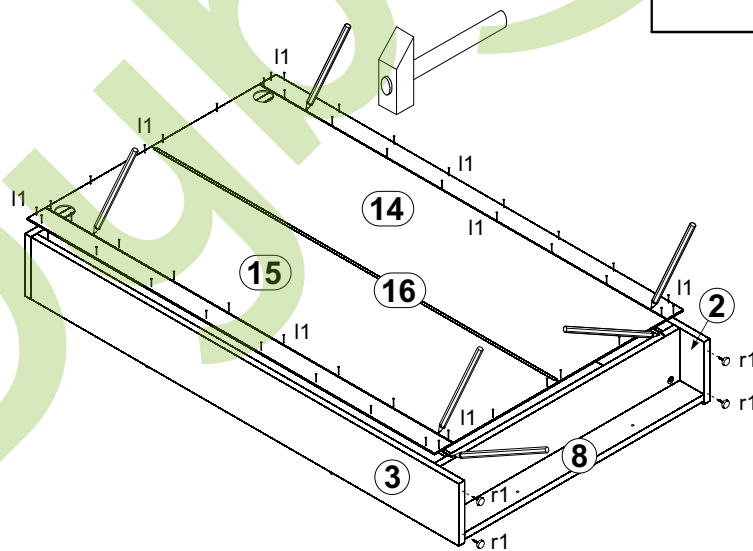
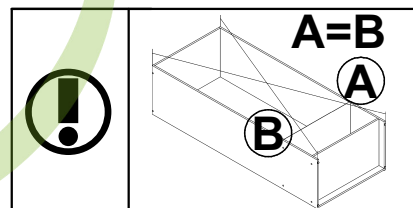

7

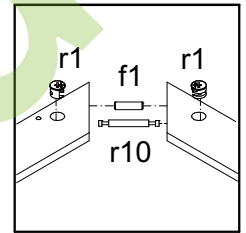
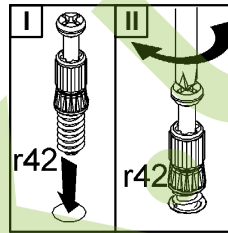
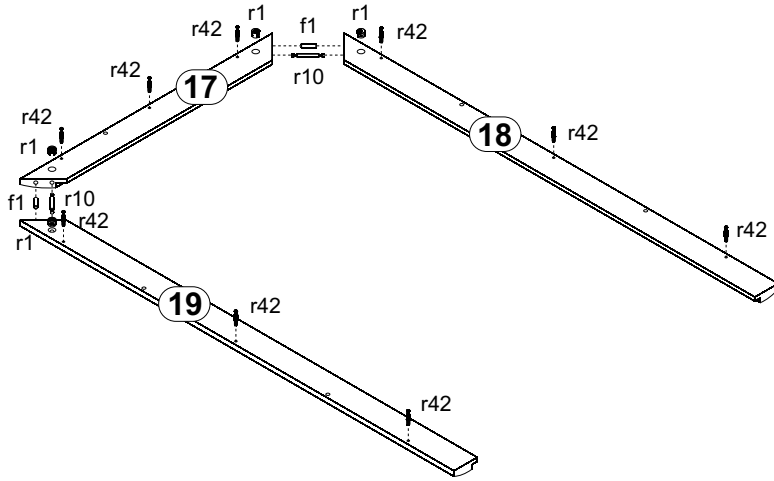

8

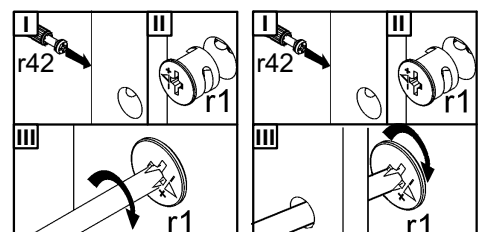
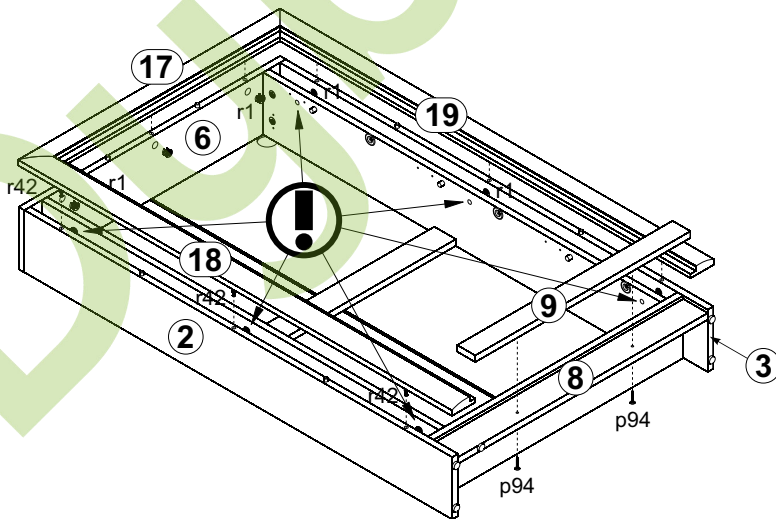

9

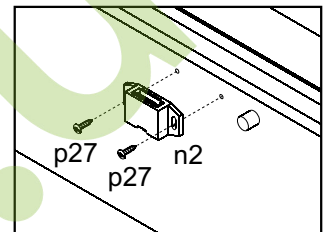
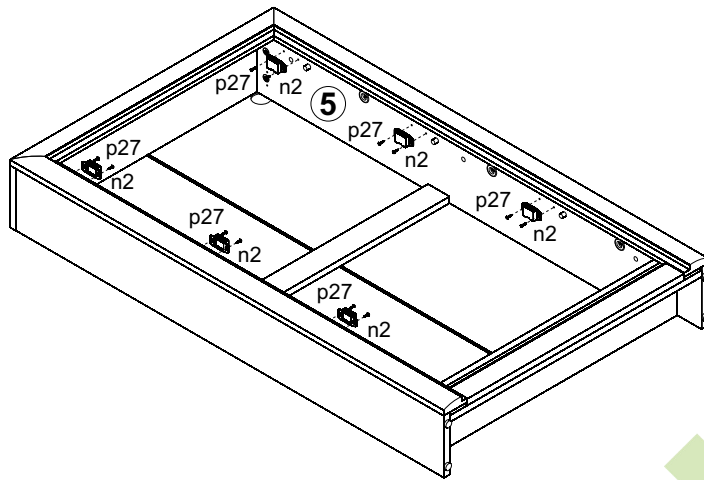

10

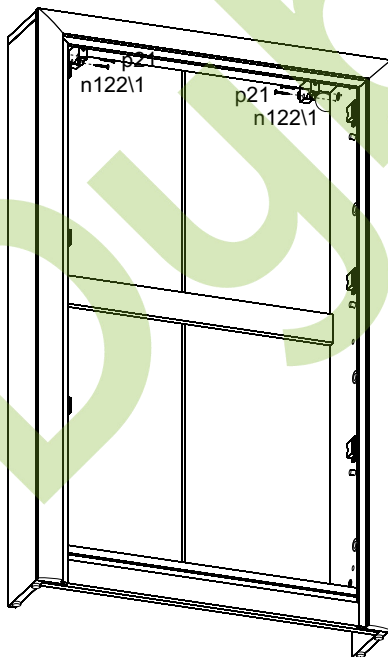

72 557 mm 72

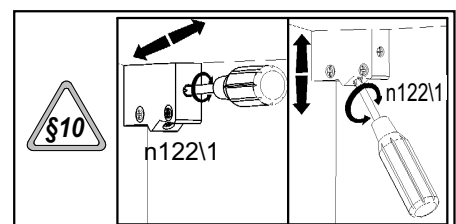
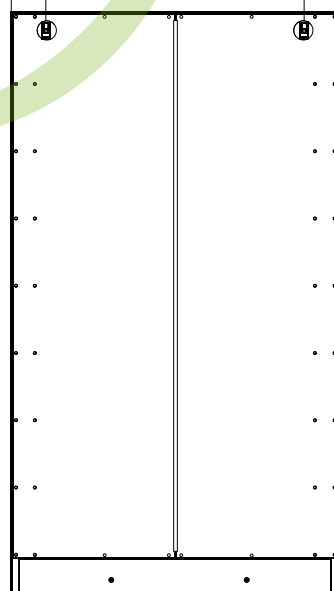

11

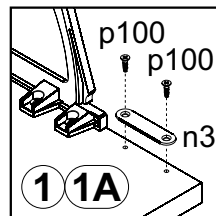
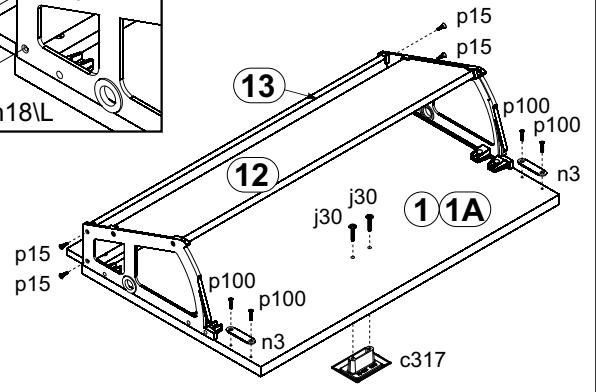
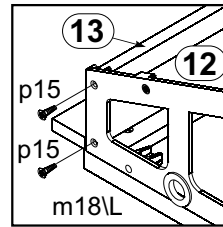
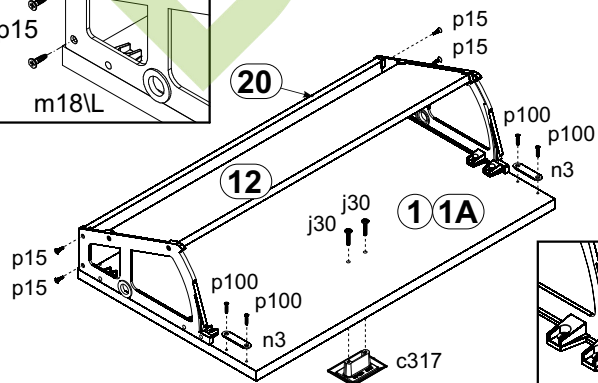
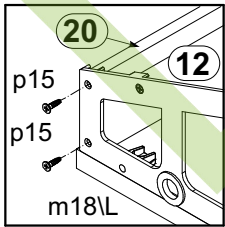
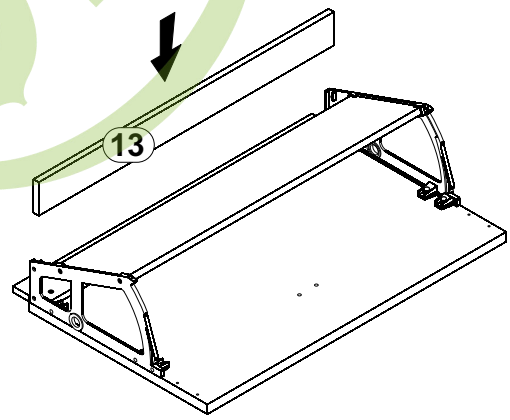
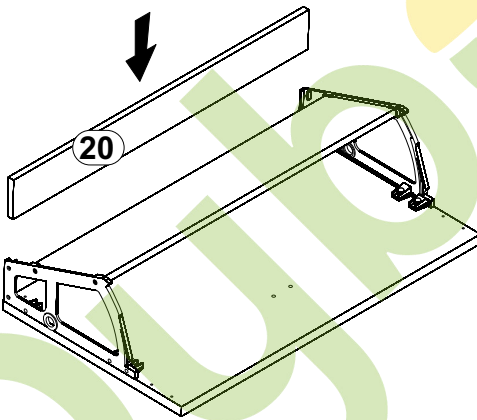
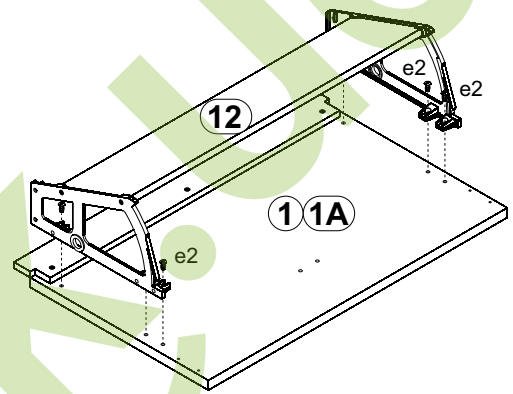
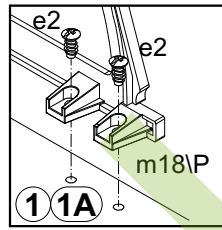
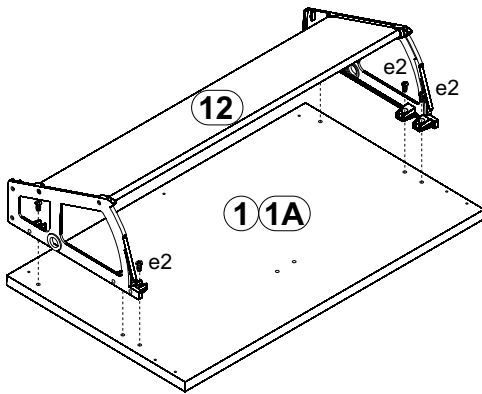
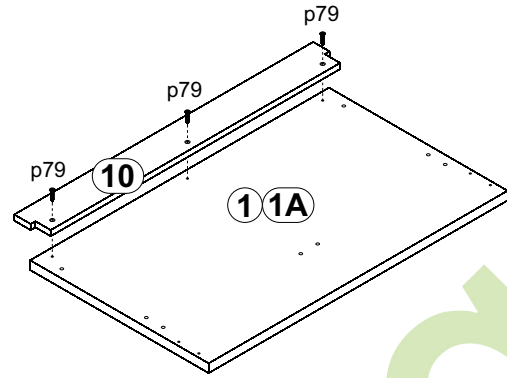
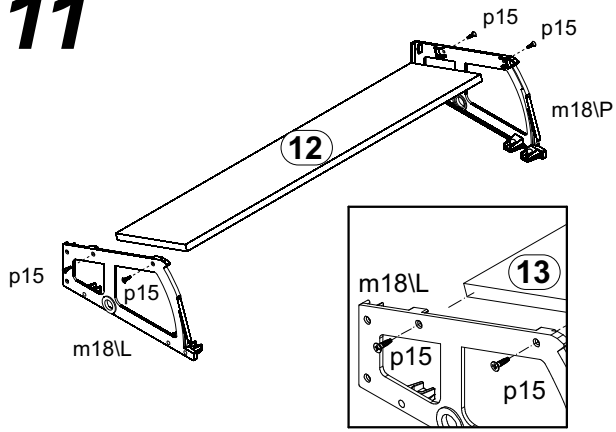

12

