

I Шкаф / Шкаф SZF2D

A	B	C	D		
1	M111-001	1865	331	8/10	→ Фасад ДСП
1A	M111-001A	1865	331	8/10	→ Фасад МДФ
2	M111-101	1999	495	1/10	
3	M111-102	1999	495	1/10	
4	M111-301	766	495	2/10	
5	M111-302	766	495	2/10	
6	M111-401	766	68	2/10	
7	M111-501	2000	65	4/10	
8	M111-502	2000	65	4/10	
9	M111-503	800	65	4/10	
10	M111-901	1926	793	6/10	
11	dr-761	761	22	2/10	

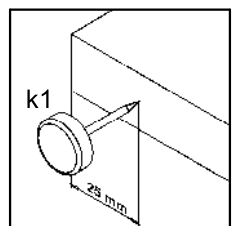

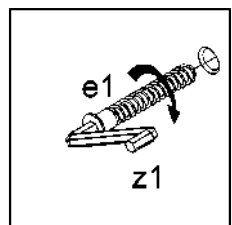
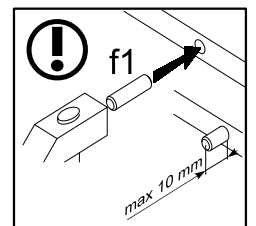
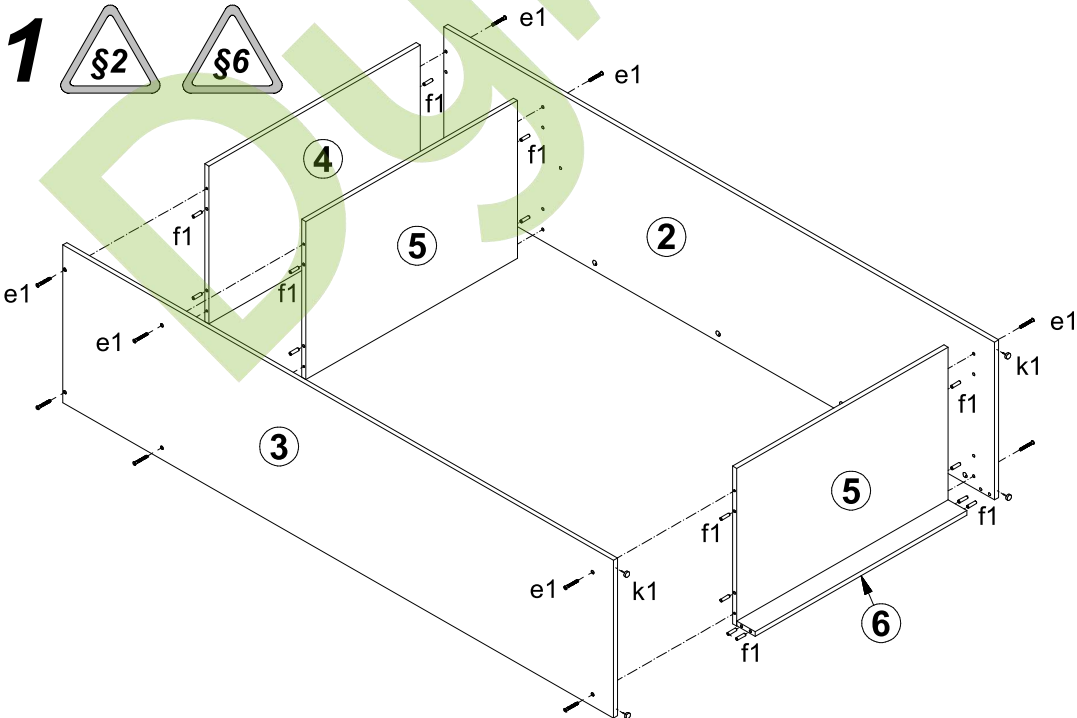
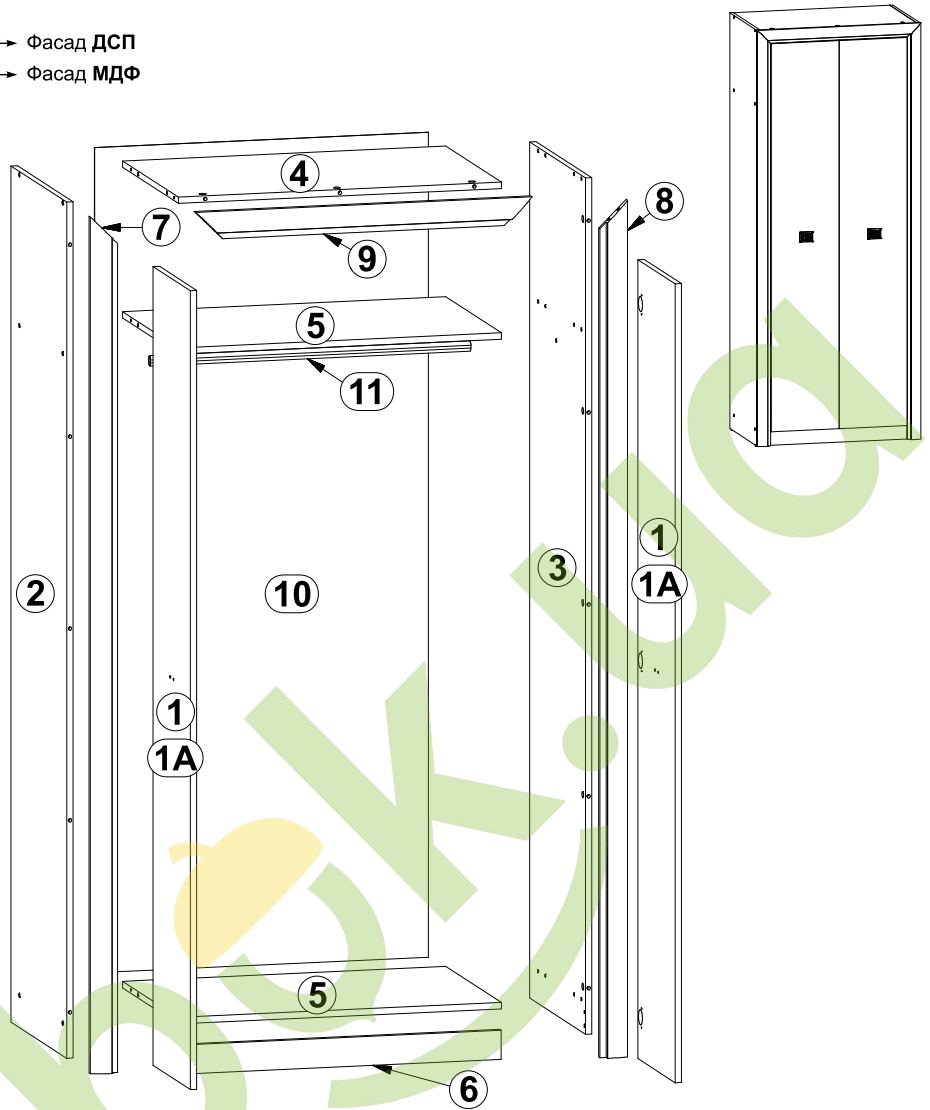
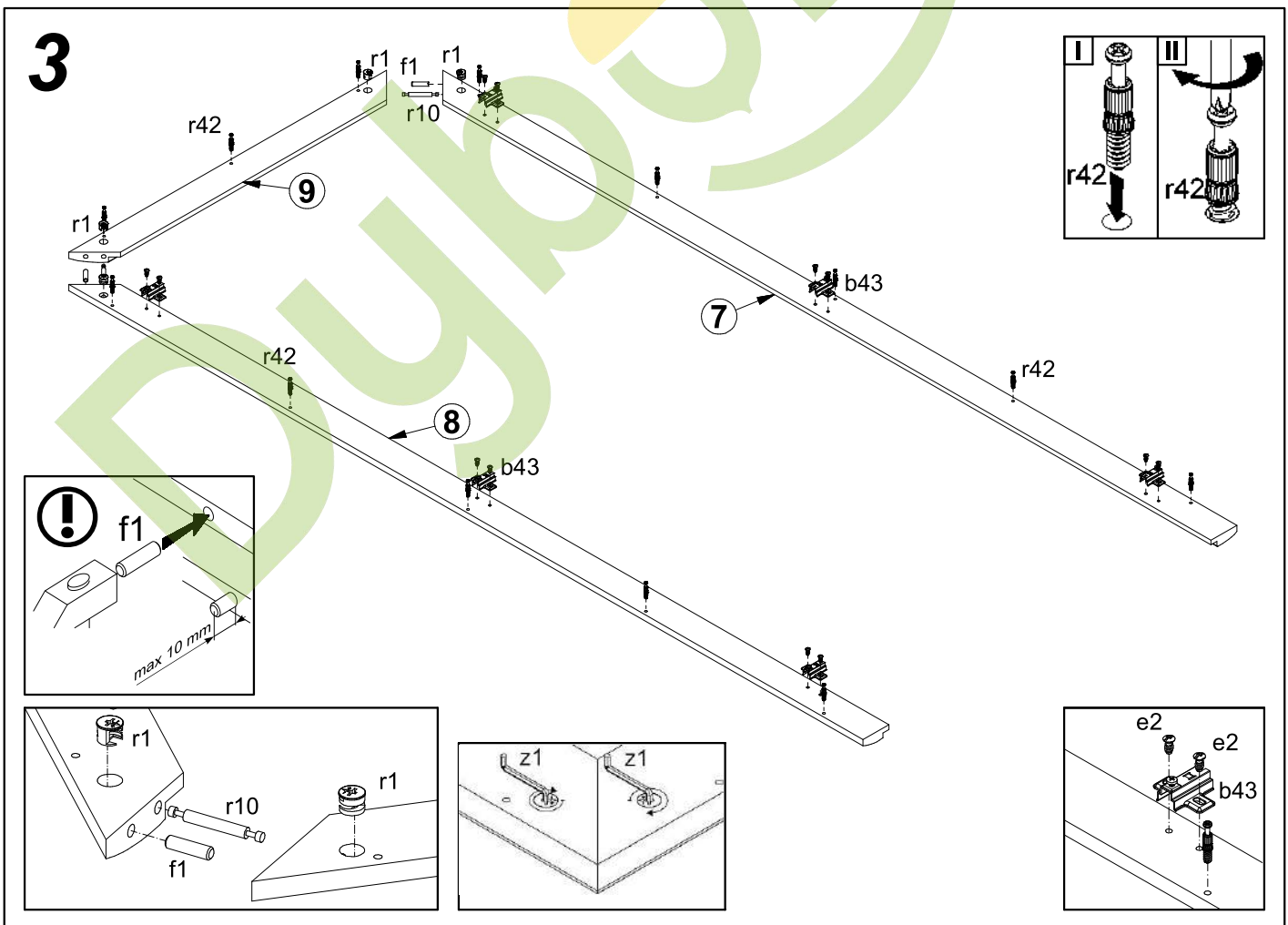
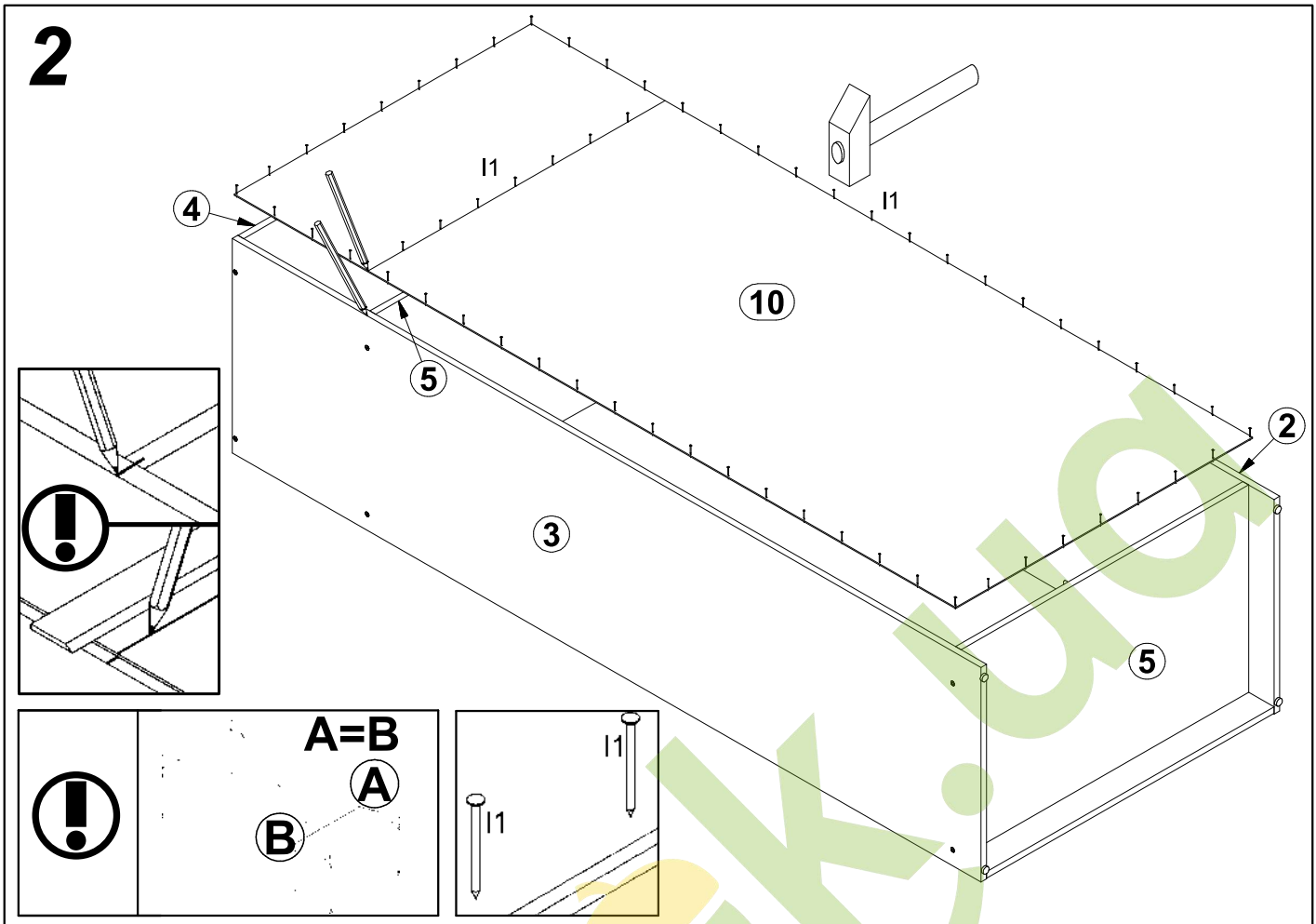

4

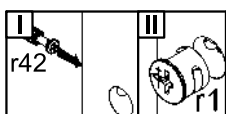
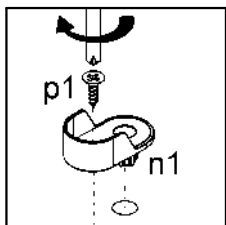
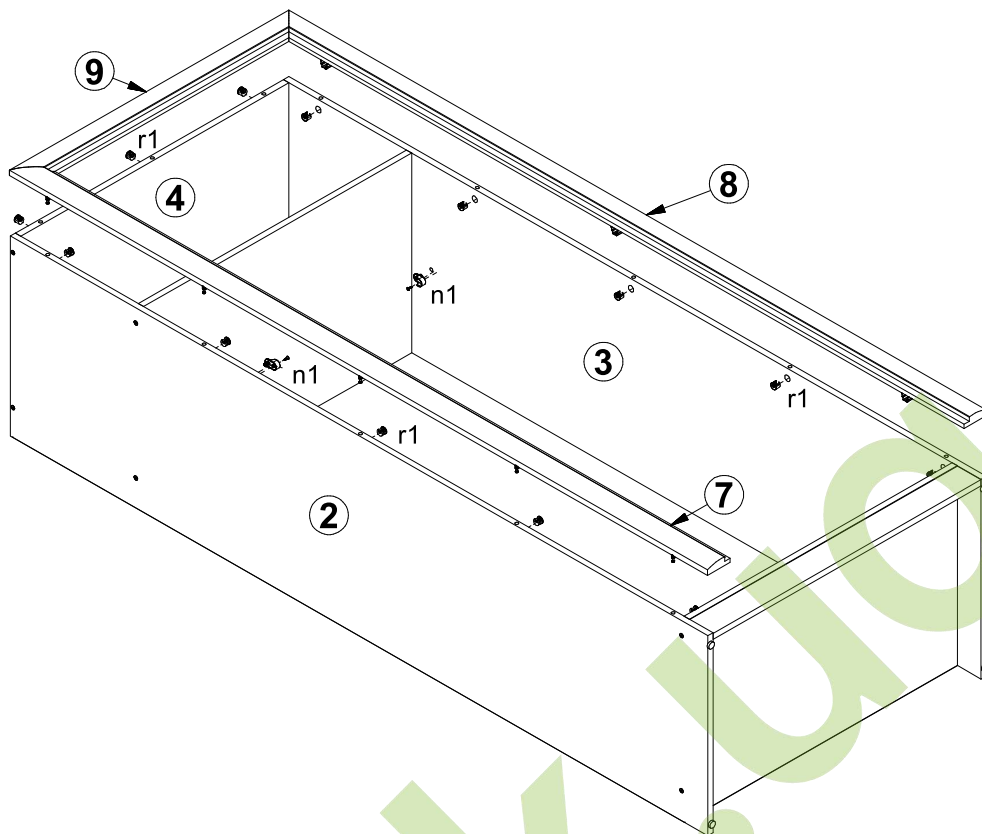

5

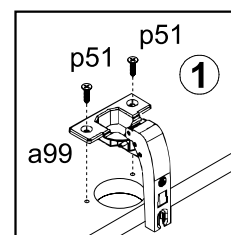
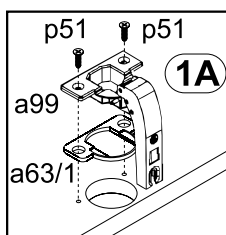
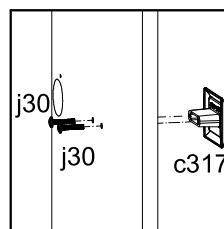
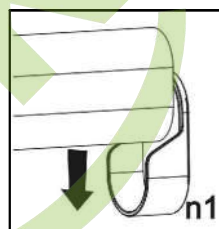
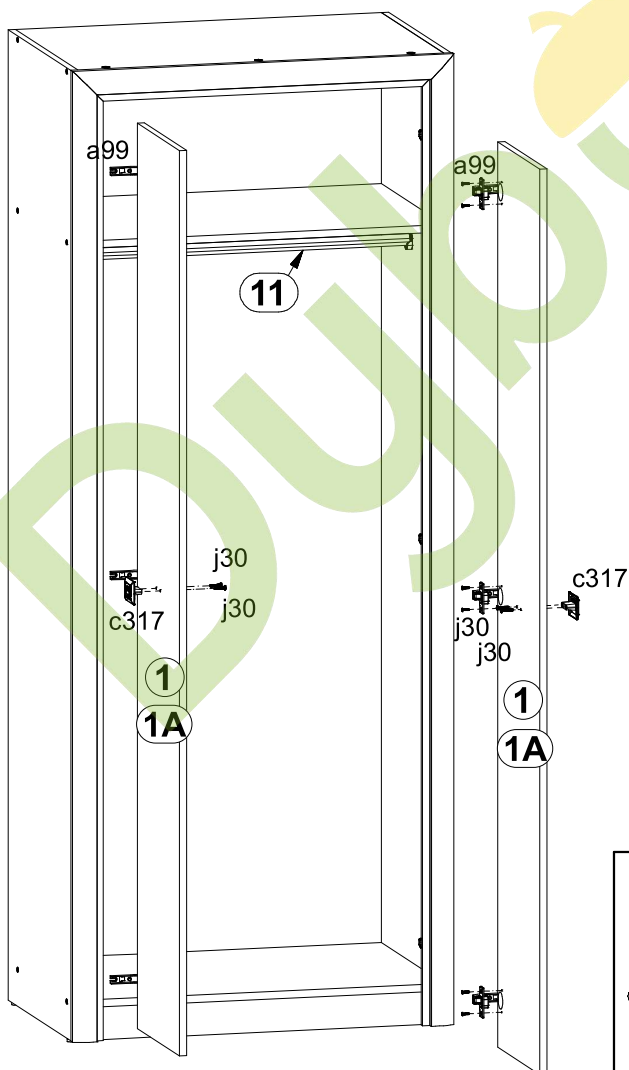

Фасад МДФ

Фасад ДСП

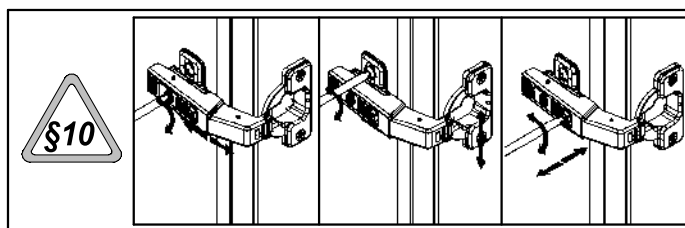
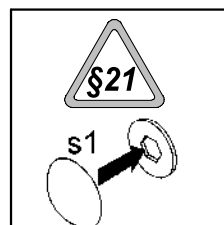
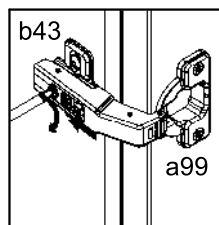

II Тумба РТВ RTV2D1S

A	B	C	D
1	M111-005	668	184 9/10
1A	M111-005A	668	184 9/10
2	M111-007	445	330 9/10
2A	M111-007A	445	330 9/10
3	M111-008	445	330 9/10
3A	M111-008A	445	330 9/10
4	M111-103	447	495 1/10
5	M111-104	447	495 1/10
6	M111-107	363	495 1/10
7	M111-108	363	495 1/10
8	M111-201	1717	495 2/10

→ Фасад ДСП
 → Фасад МДФ
 → Фасад ДСП
 → Фасад МДФ
 → Фасад ДСП
 → Фасад МДФ



A	B	C	D
9	M111-304	1684	495 2/10
10	M111-308	662	495 2/10
11	M111-402	1684	68 2/10
12	M111-504	464	65 4/10
13	M111-505	464	65 4/10
14	M111-506	1718	65 4/10
15	M111-902	390	1711 6/10
16	M111-903	620	449 6/10
17	M111-550	450	120 3/10
18	M111-551	450	120 3/10
19	M111-552	605	120 3/10

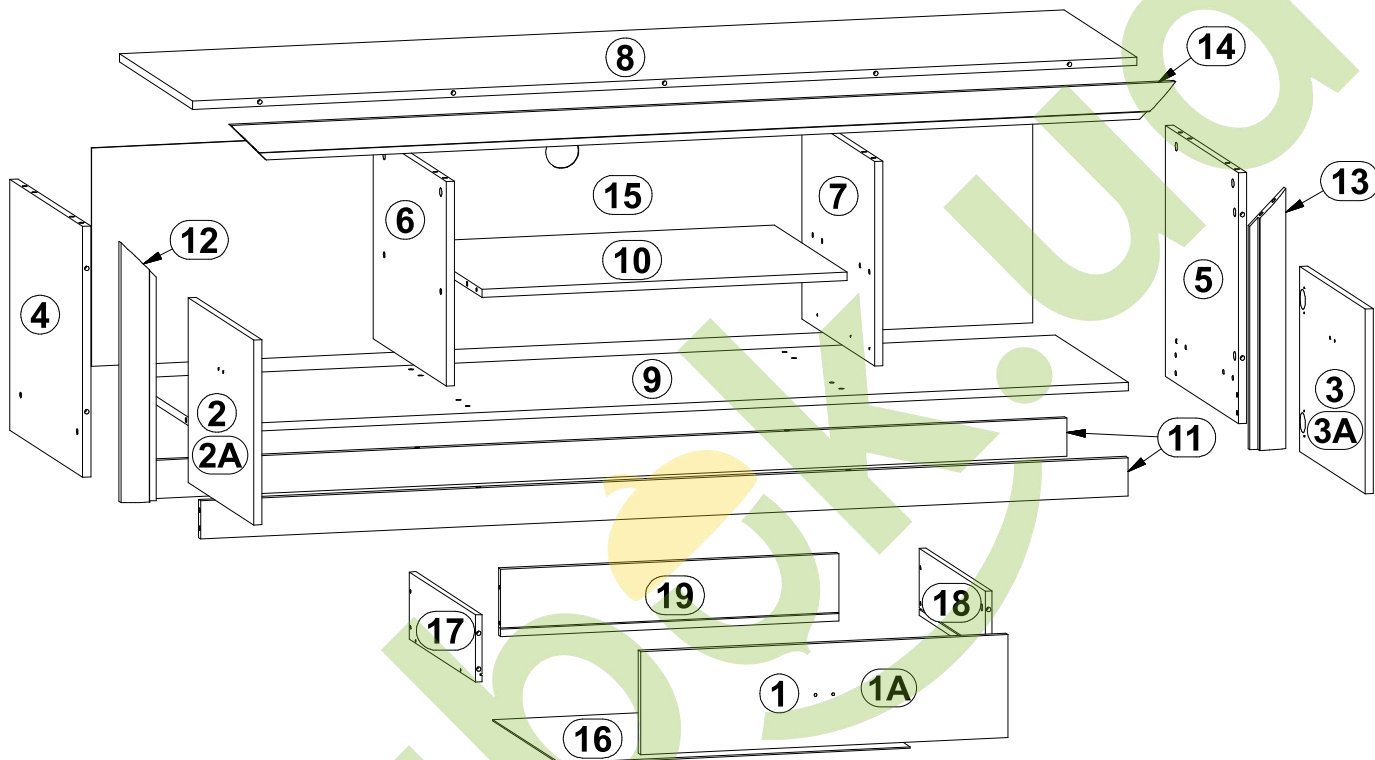
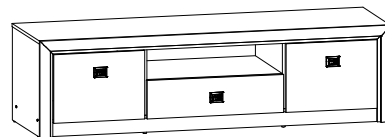

6

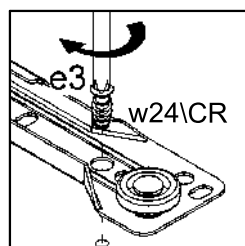
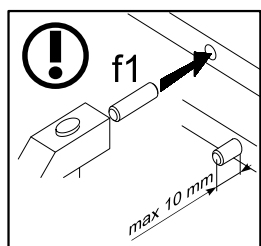
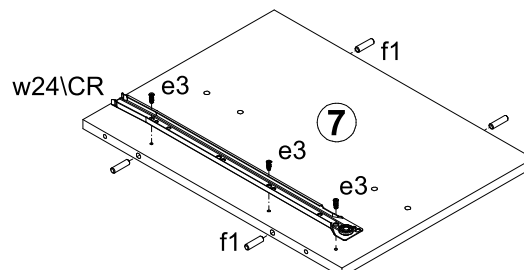
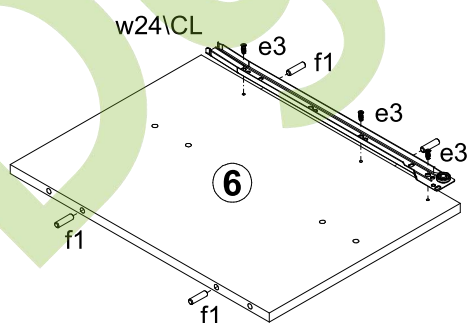

7

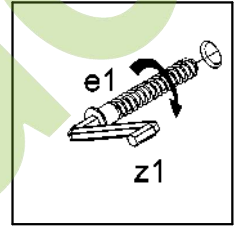
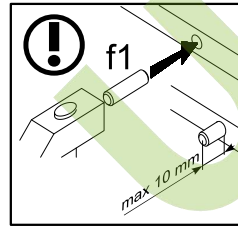
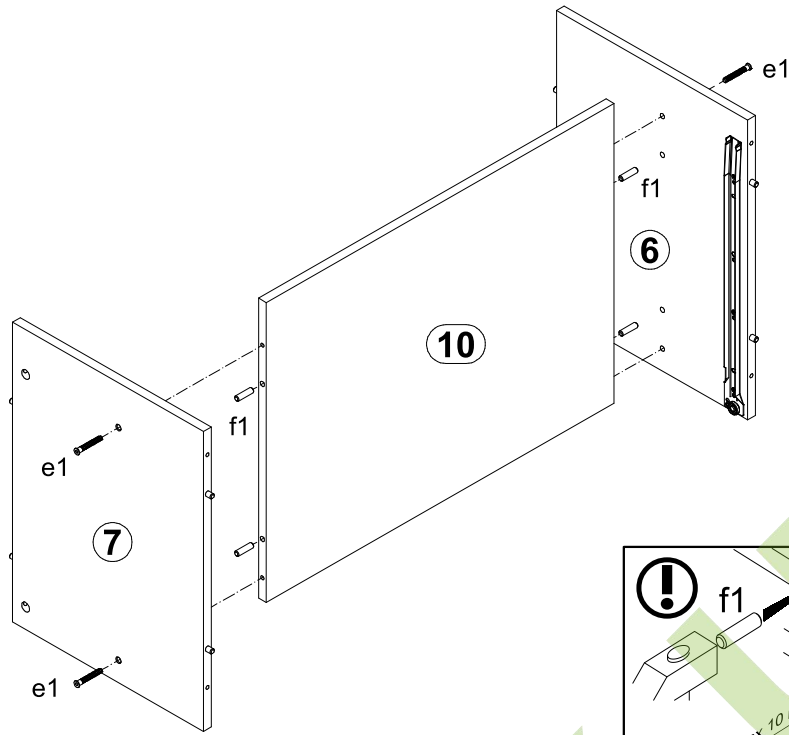

8

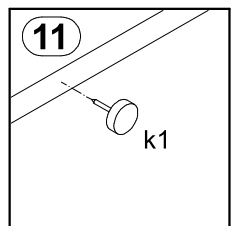
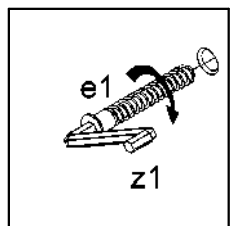
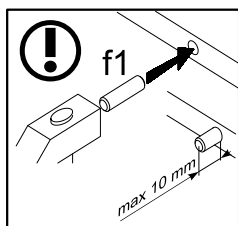
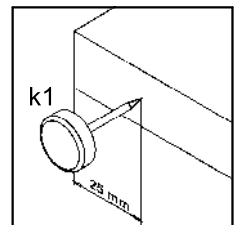
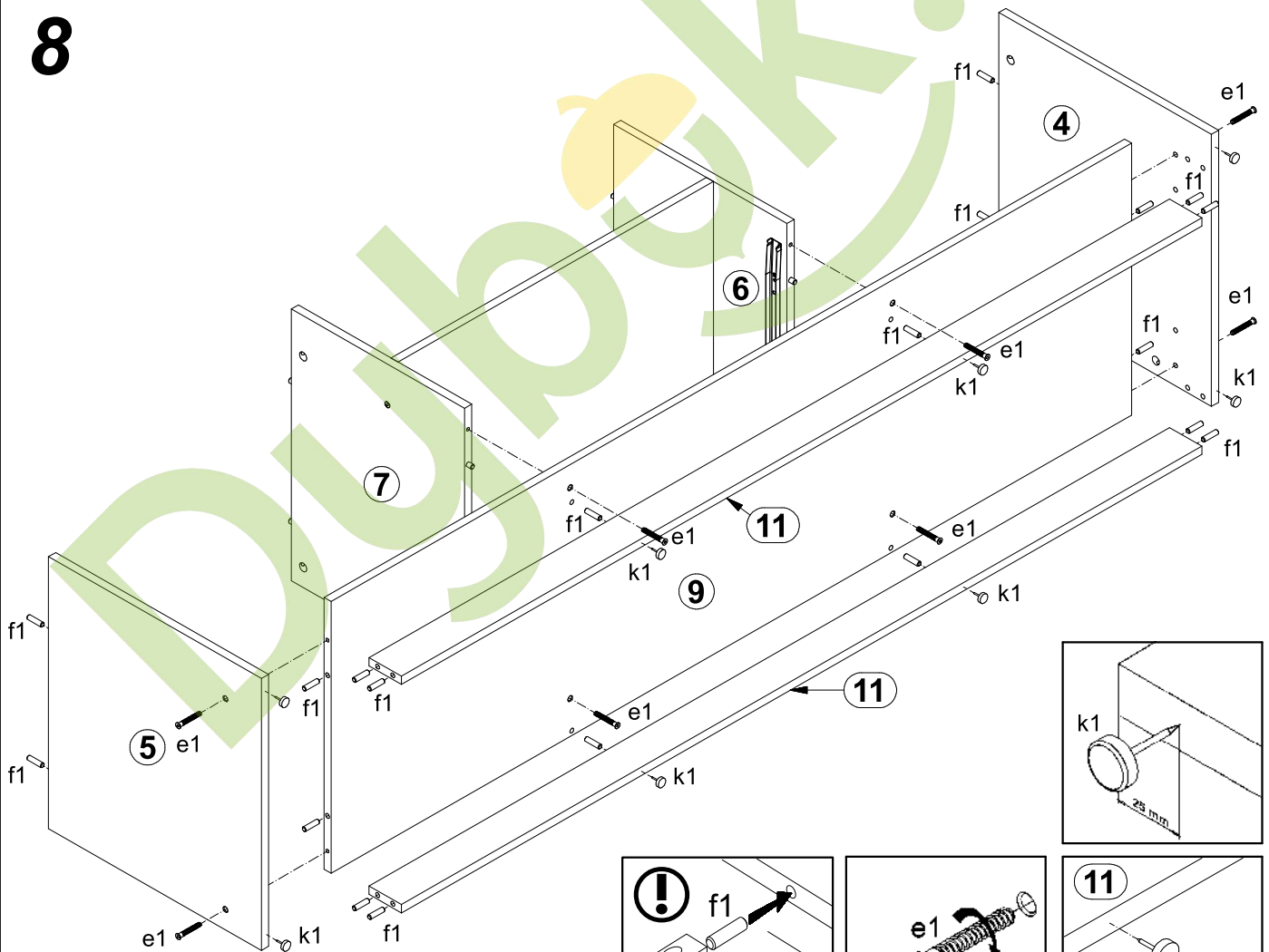

9

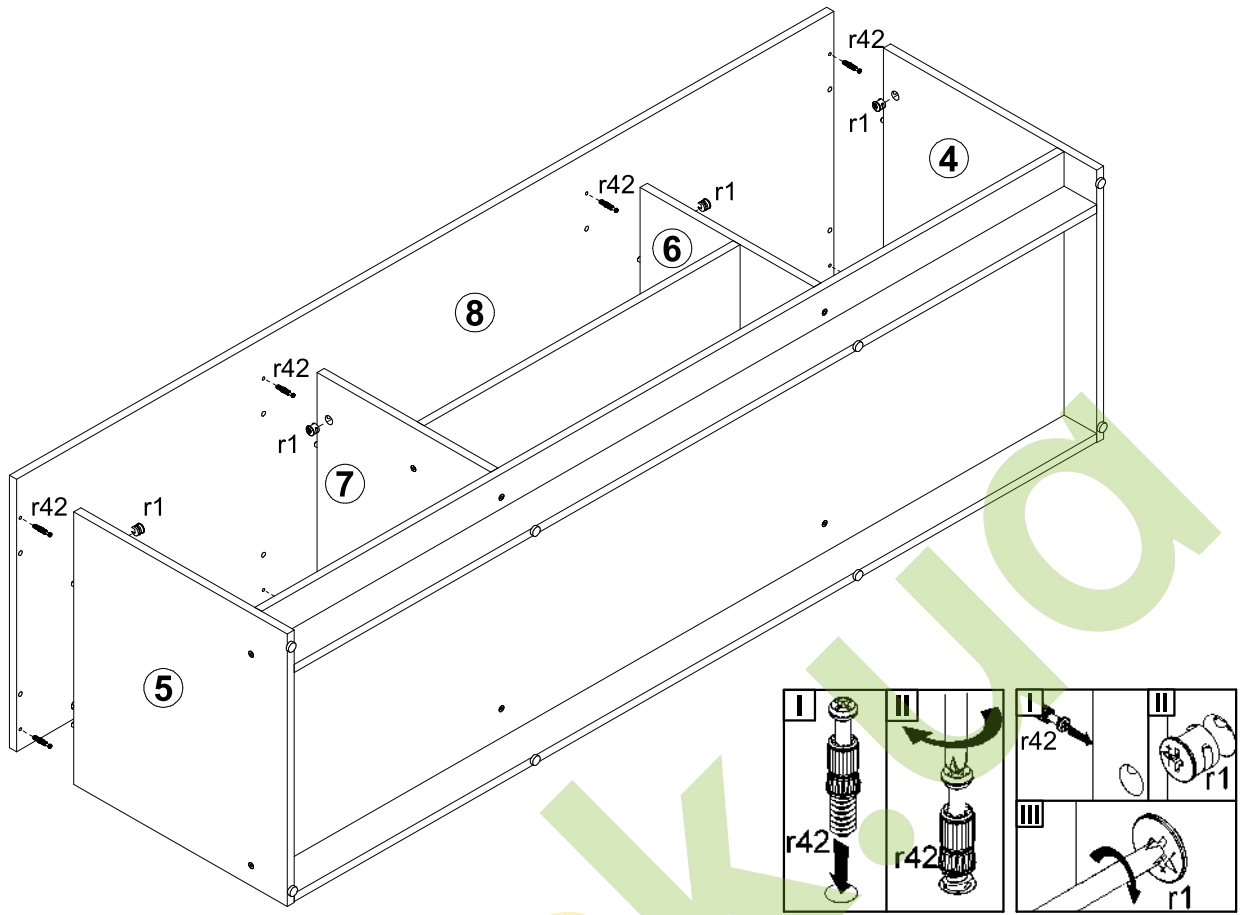

10

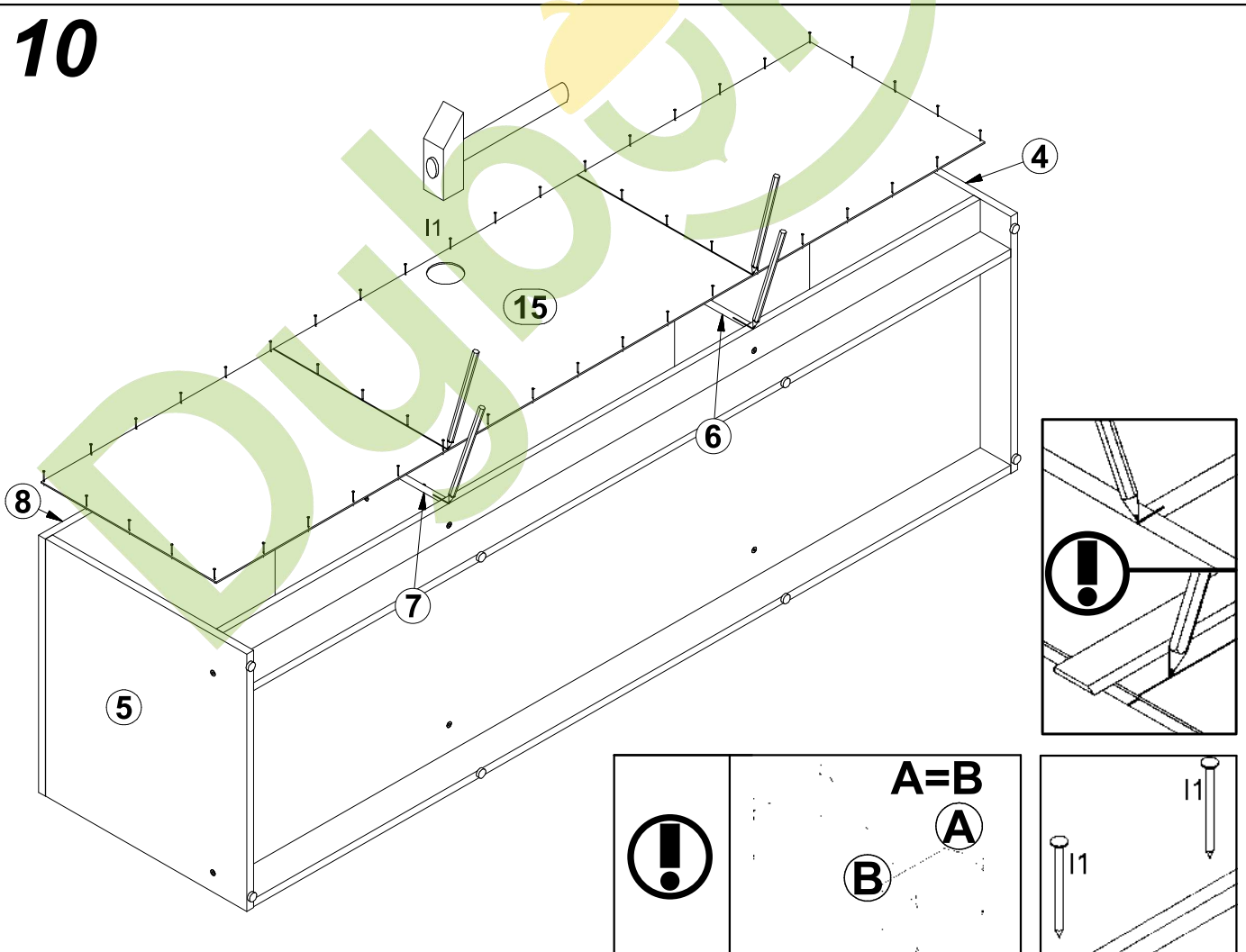

11

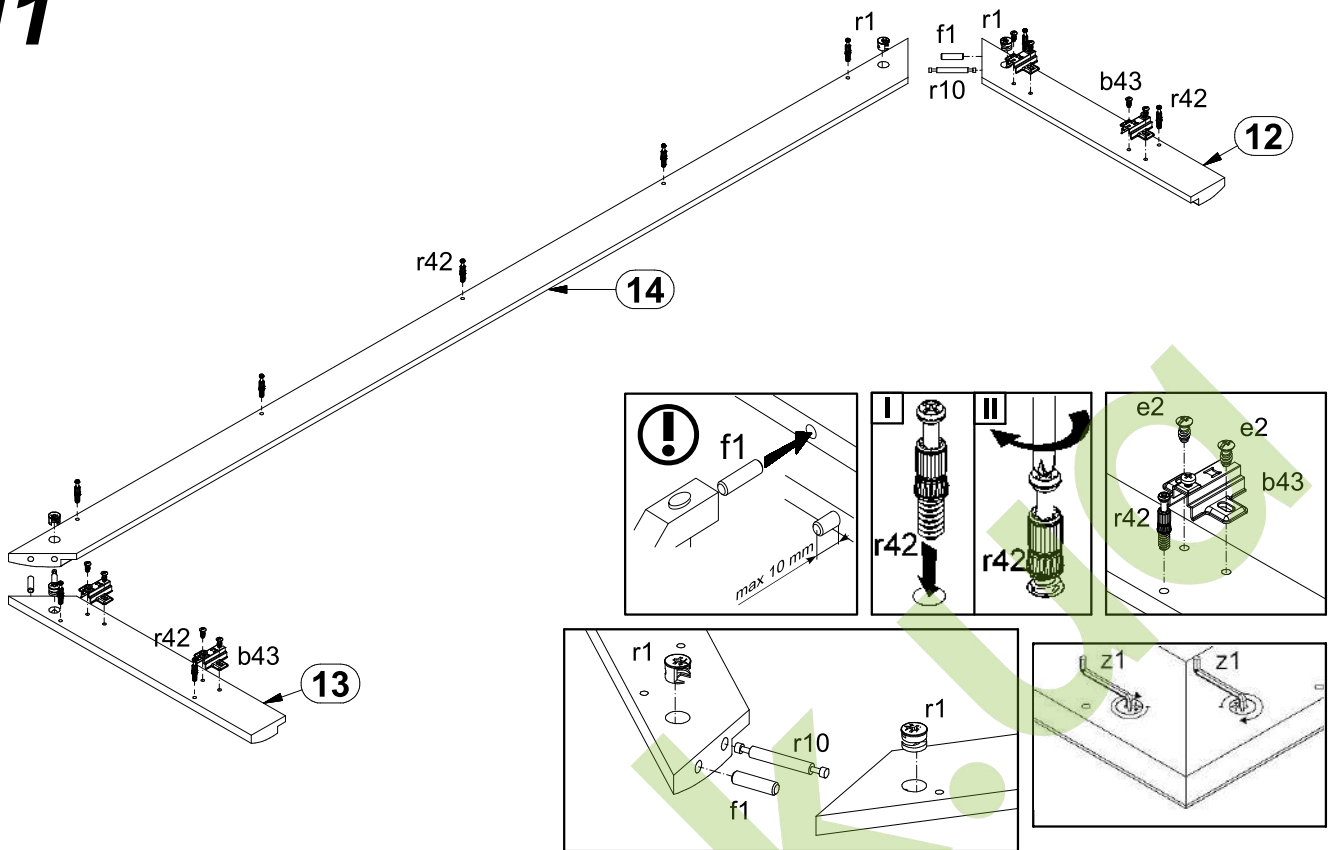

12

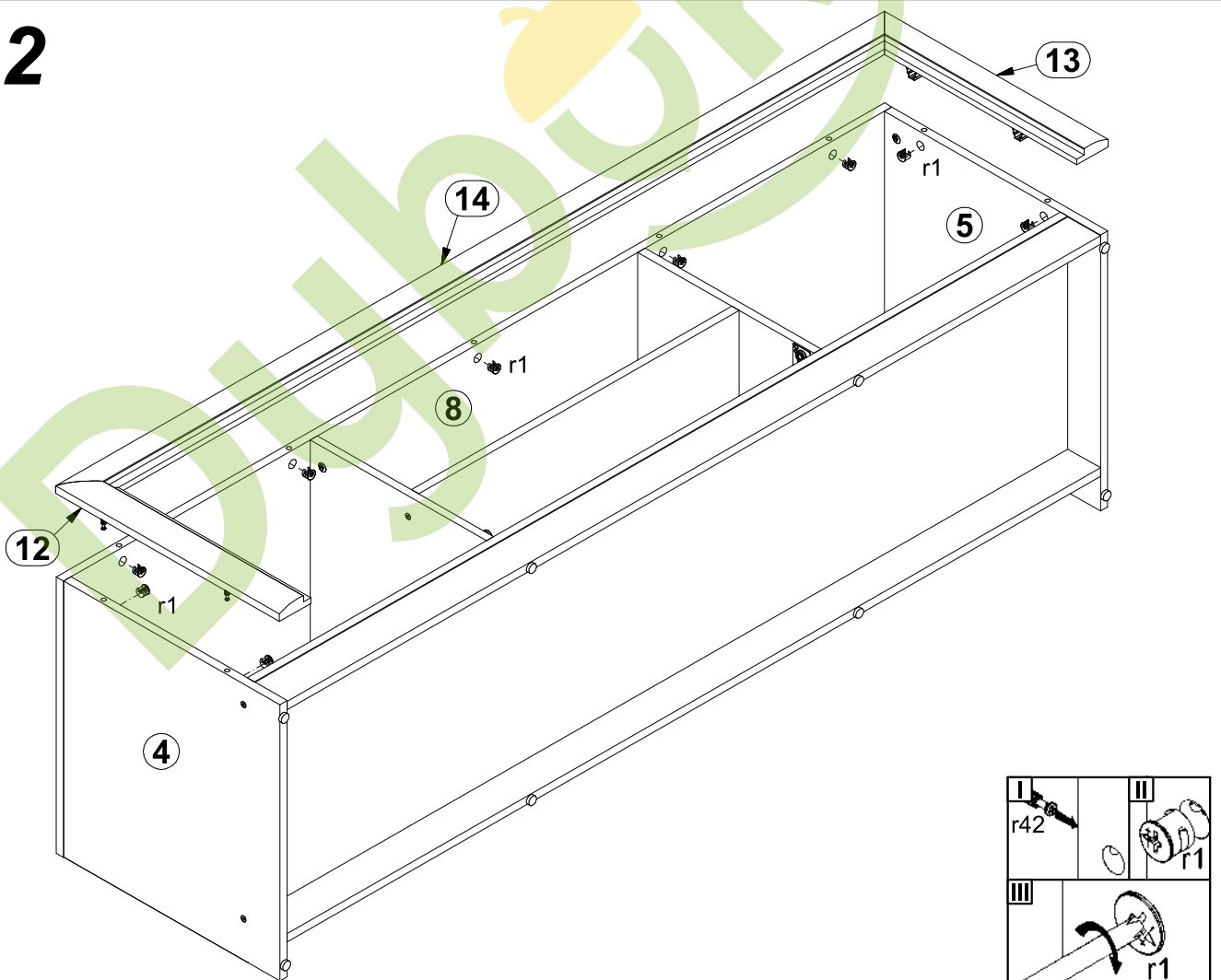

13

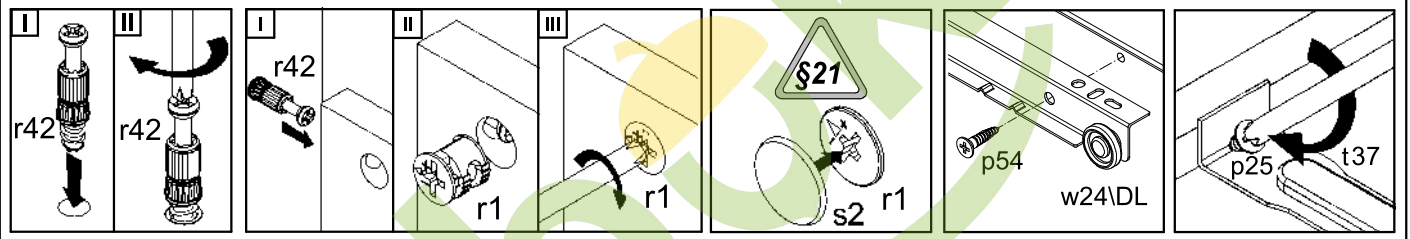
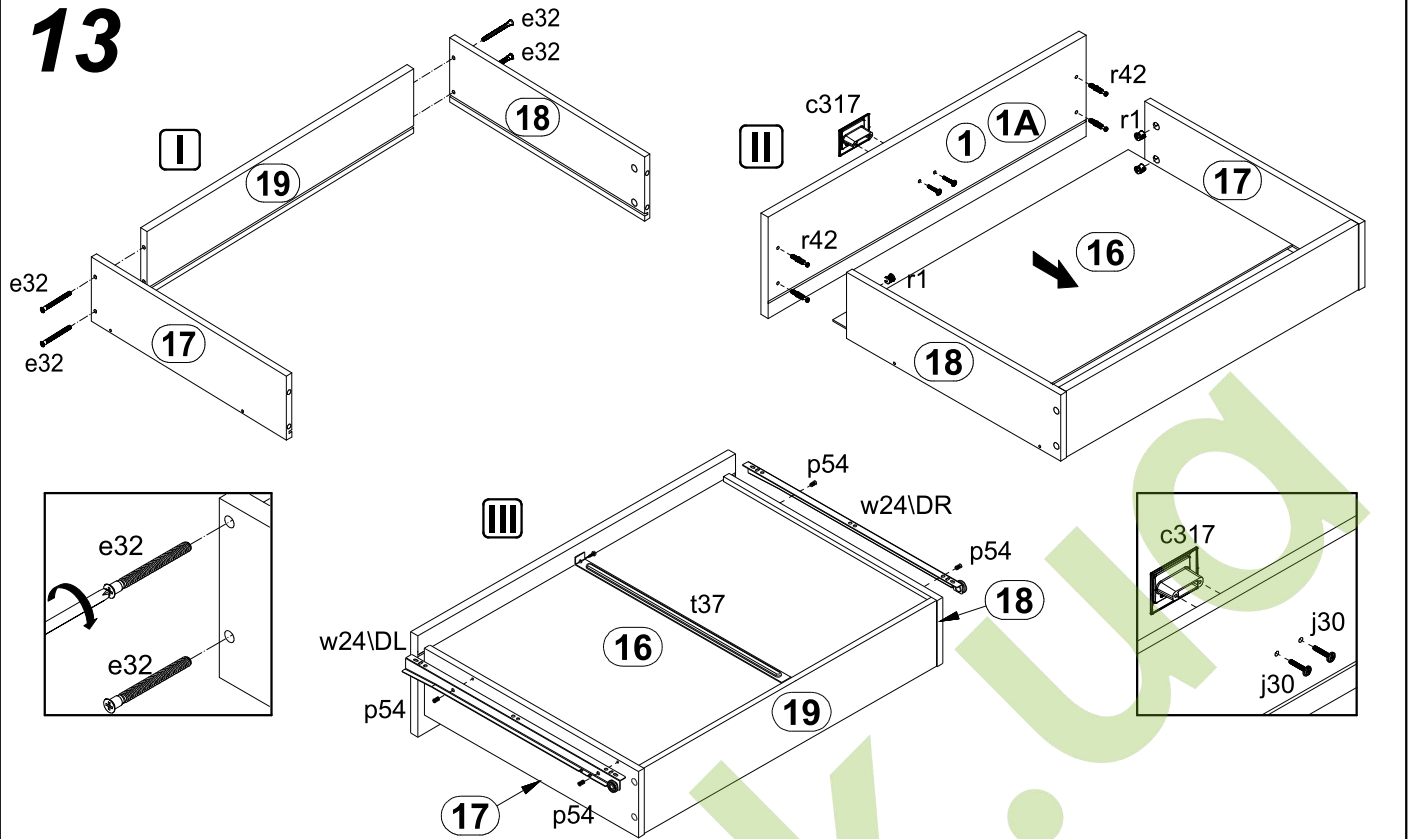

14



Надставка NAD/114

A	B	C	D
1	M111-113	1184	243 1/10
2	M111-114	1184	243 1/10
3	M111-115	194	180 2/10
4	M111-203	1136	243 1/10
5	M111-311	1103	243 1/10
6	M111-312	1103	180 2/10

A	B	C	D
7	M111-405	1103	68 2/10
8	M111-514	366	65 4/10
9	M111-515	1137	65 4/10
10	M111-516	1137	65 4/10
11	M111-907	618	1130 6/10
12	M111-908	526	1130 6/10

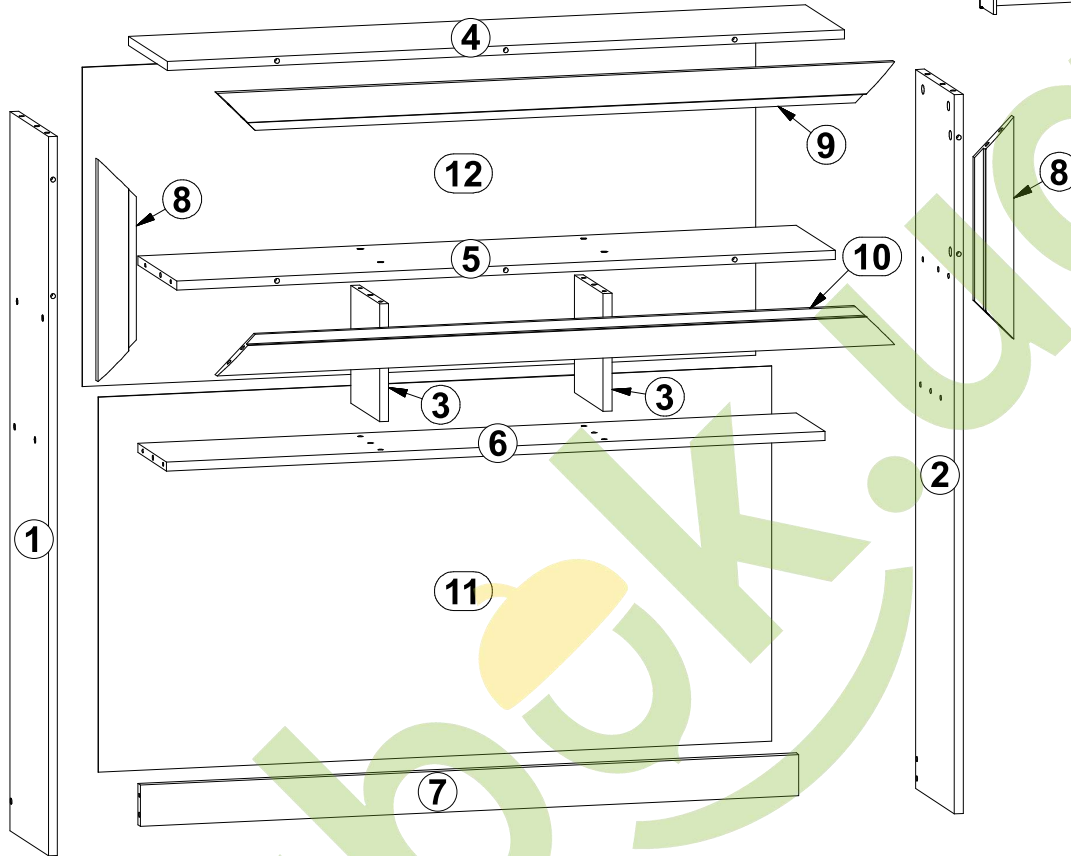
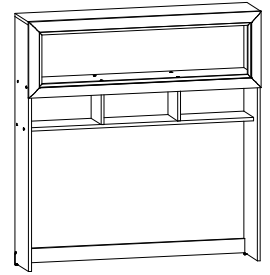

15

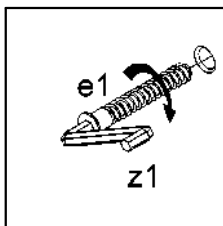
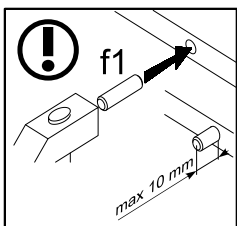
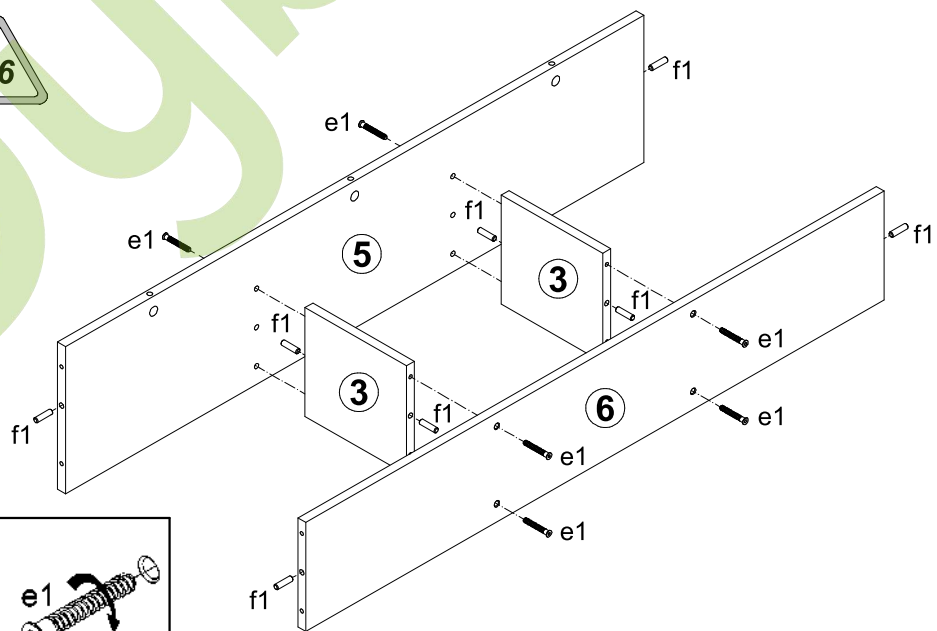

18

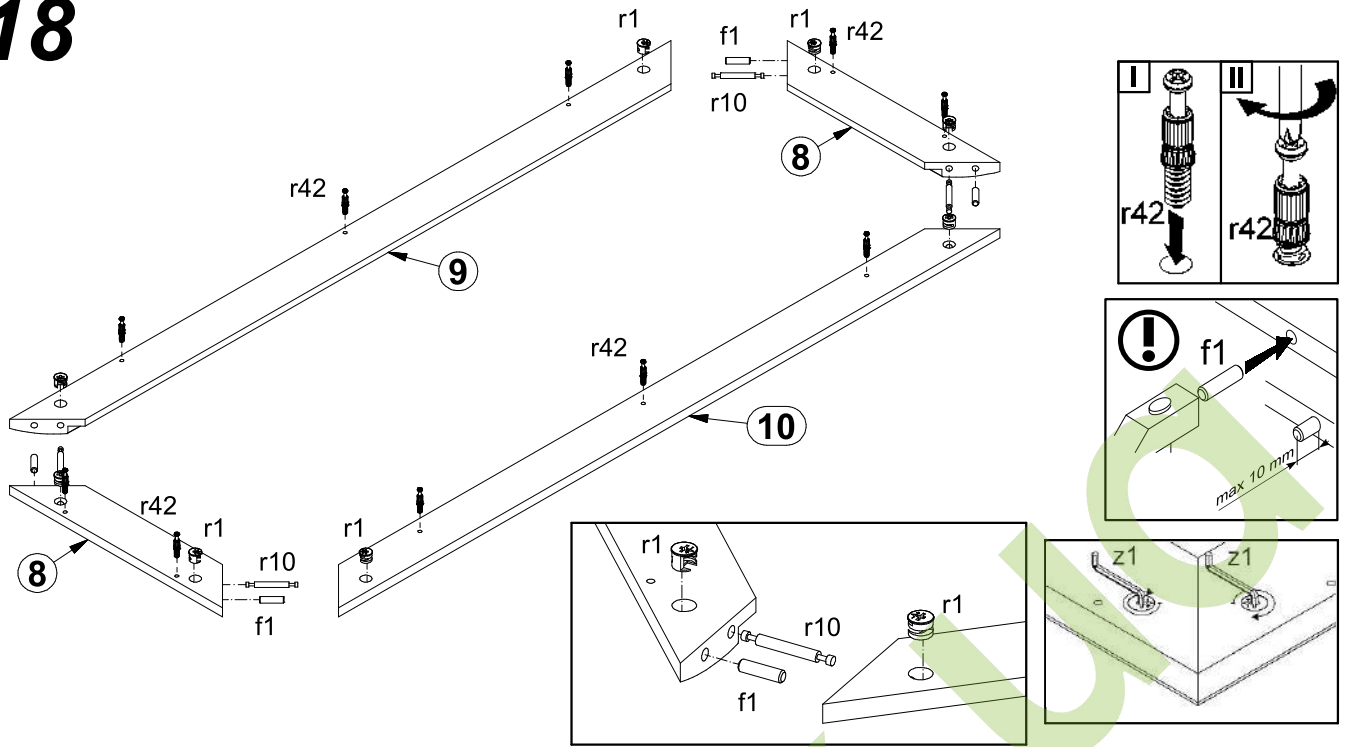

19

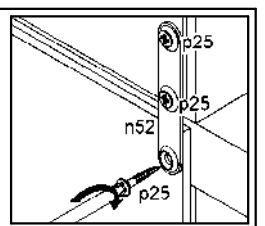
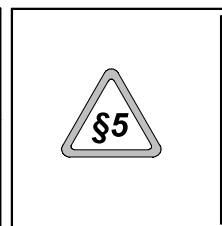
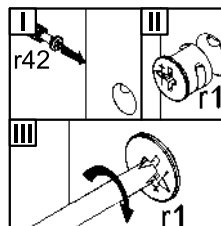
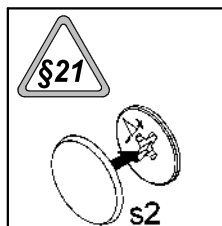
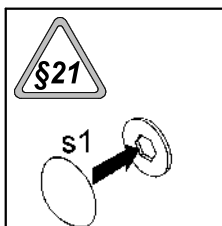
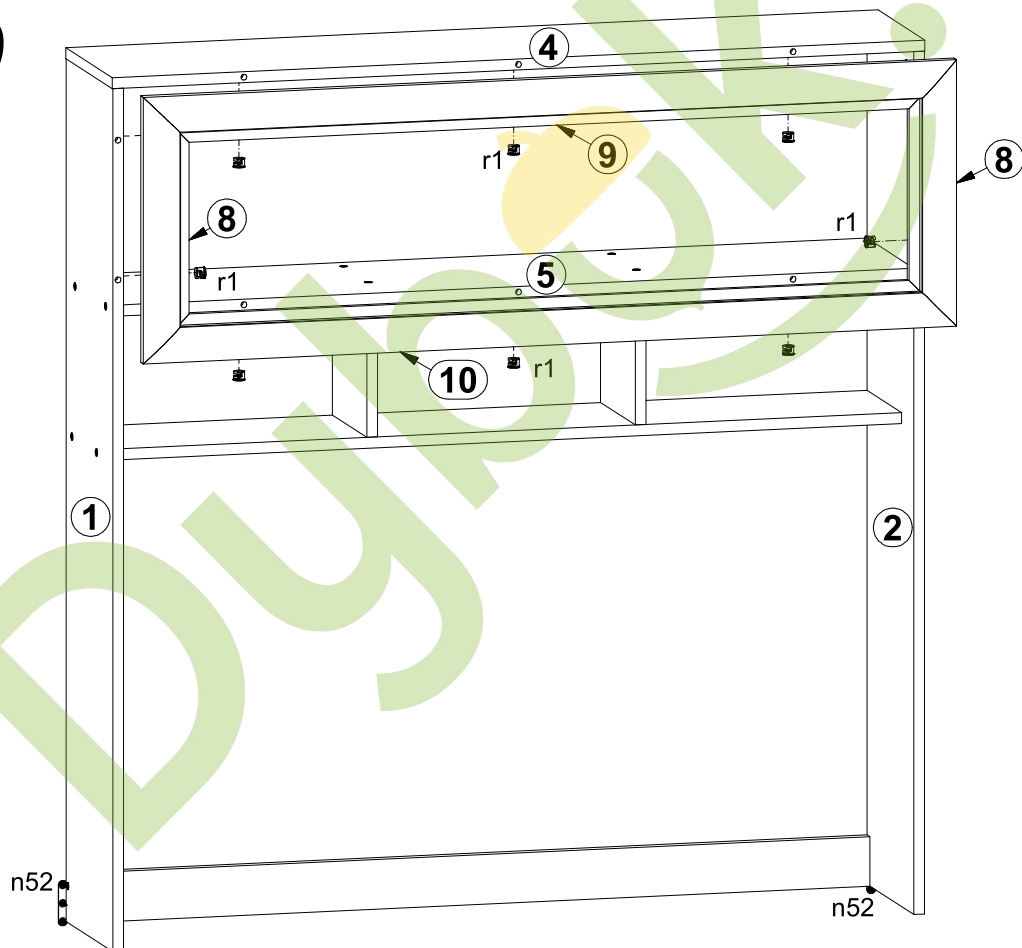

IV Надставка NAD1D2S

A	B	C	D
1	M111-002	445	365 9/10
1A	M111-002A	445	365 9/10
2	M111-006	445	184 9/10
2A	M111-006A	445	184 9/10
3	M111-109	999	330 3/10
4	M111-110	999	330 3/10
5	M111-111	356	330 3/10
6	M111-112	356	330 3/10
7	M111-202	578	330 3/10
8	M111-313	545	330 3/10
9	M111-404	545	68 2/10

→ Фасад ДСП
 → Фасад МДФ
 → Фасад ДСП
 → Фасад МДФ

A	B	C	D
10	M111-406	452	60 2/10
11	M111-407	545	68 2/10
12	M111-510	581	65 4/10
13	M111-511	1016	65 4/10
14	M111-512	1016	65 4/10
15	M111-904	978	572 6/10
16	M111-905	411	299 6/10
17	M111-553	300	120 3/10
18	M111-554	300	120 3/10
19	M111-555	396	120 3/10

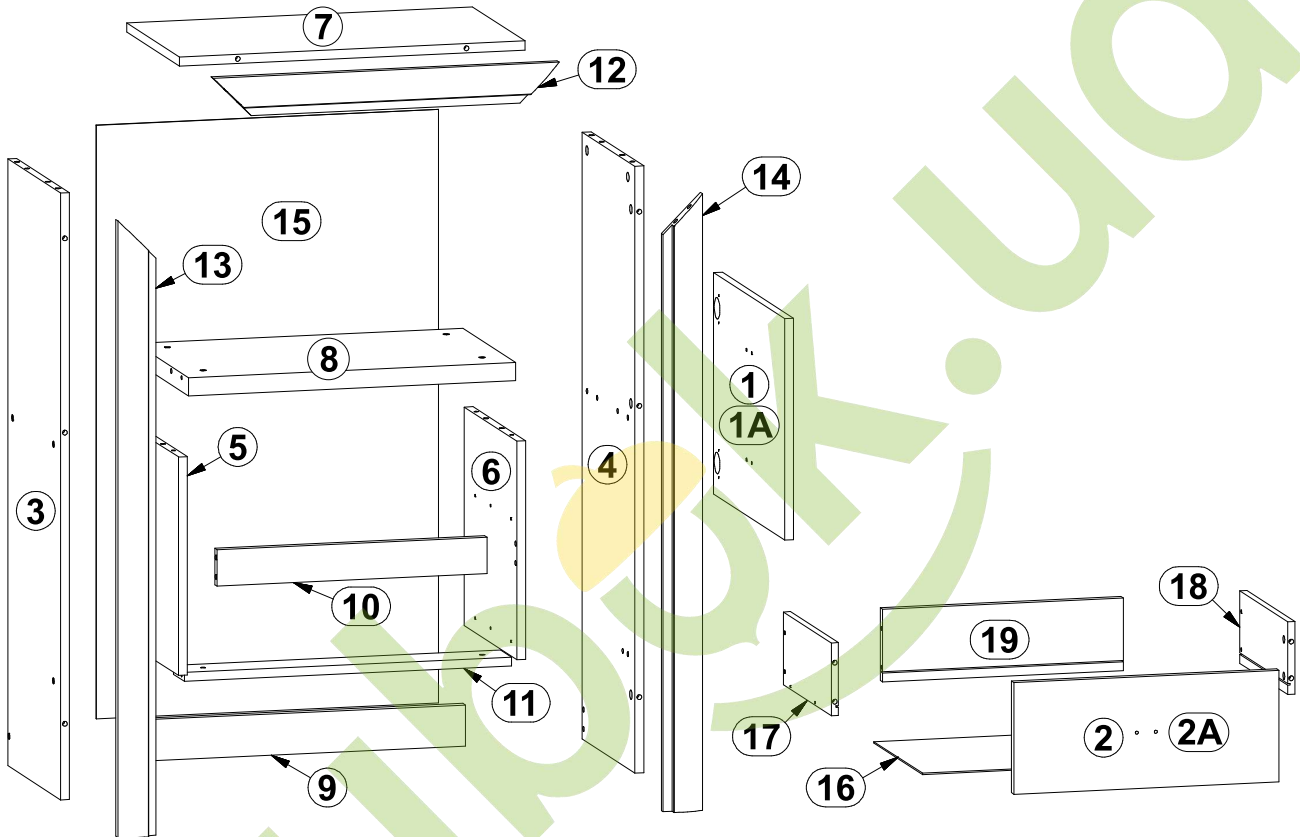
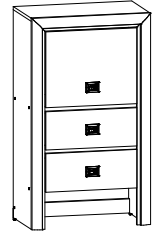

20

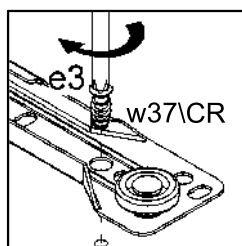
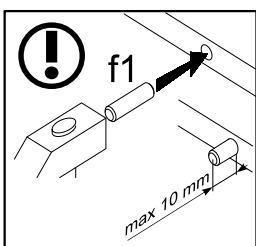
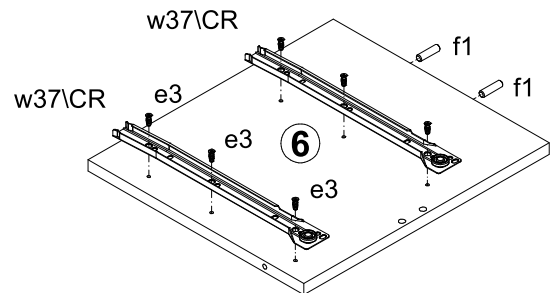
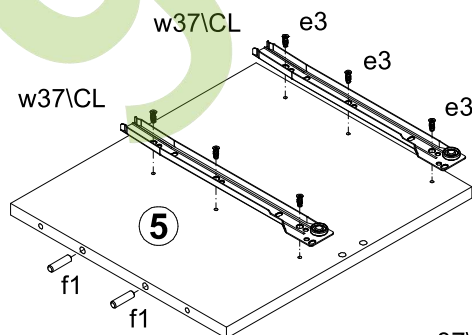

21

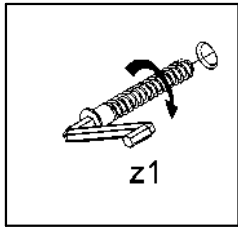
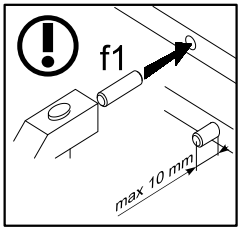
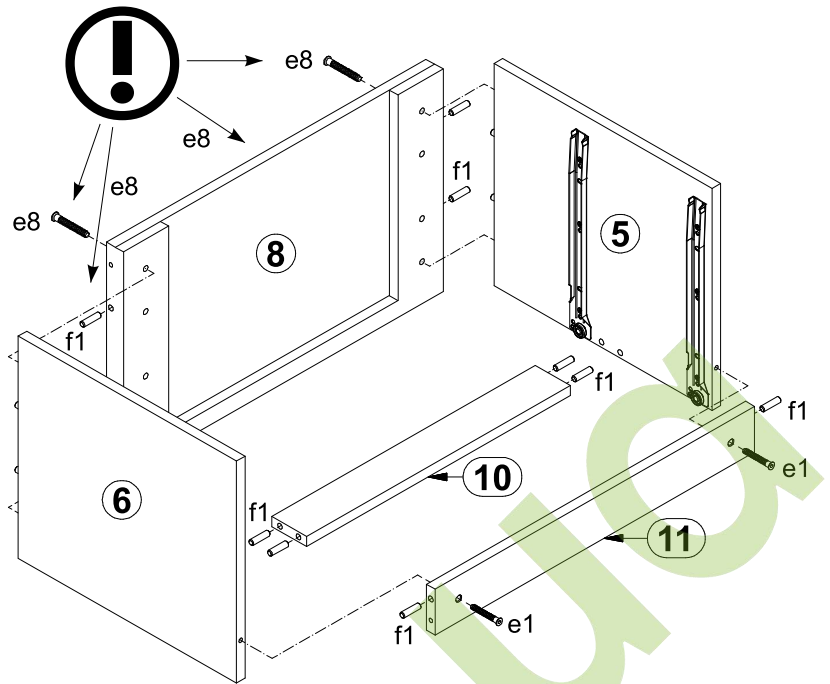

22

I

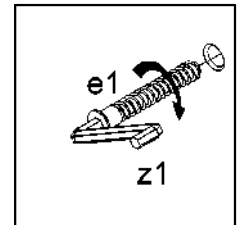
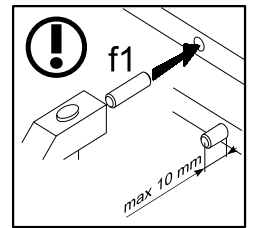
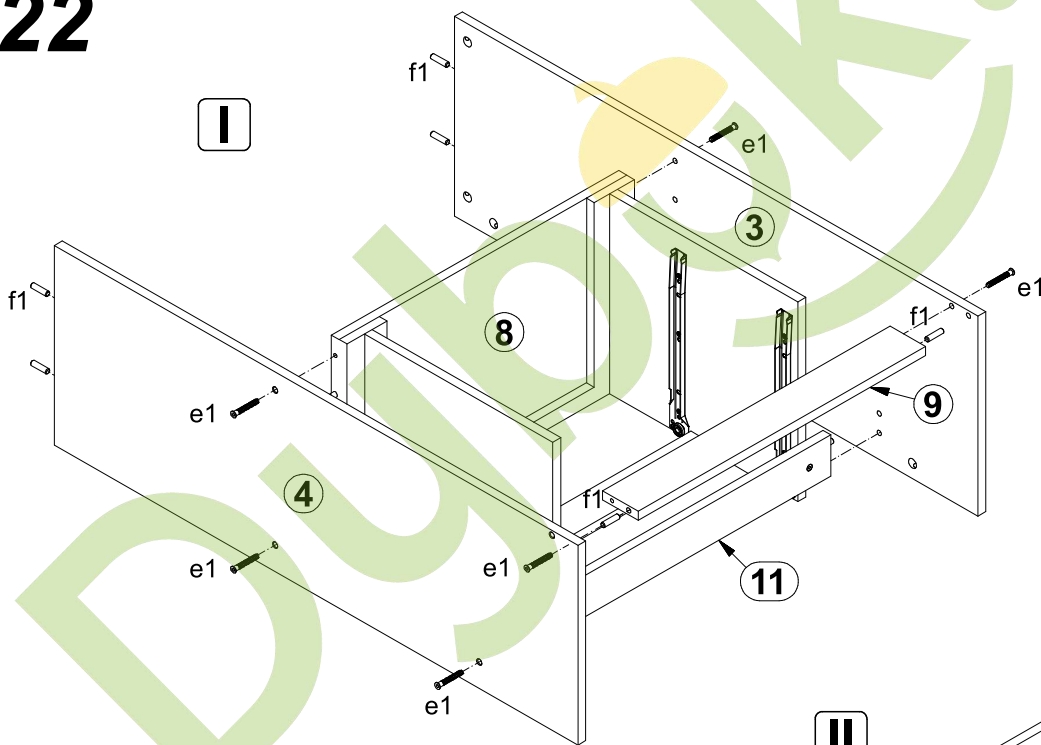

II

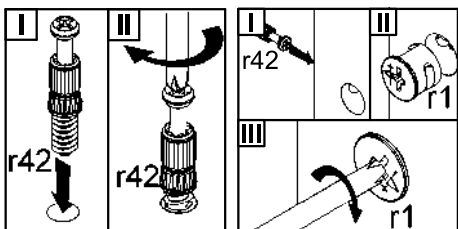
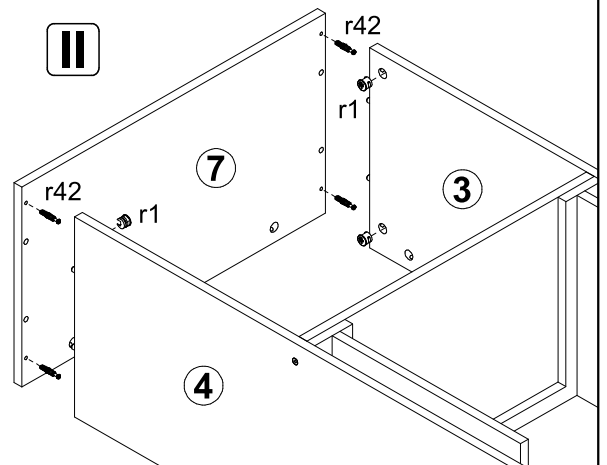

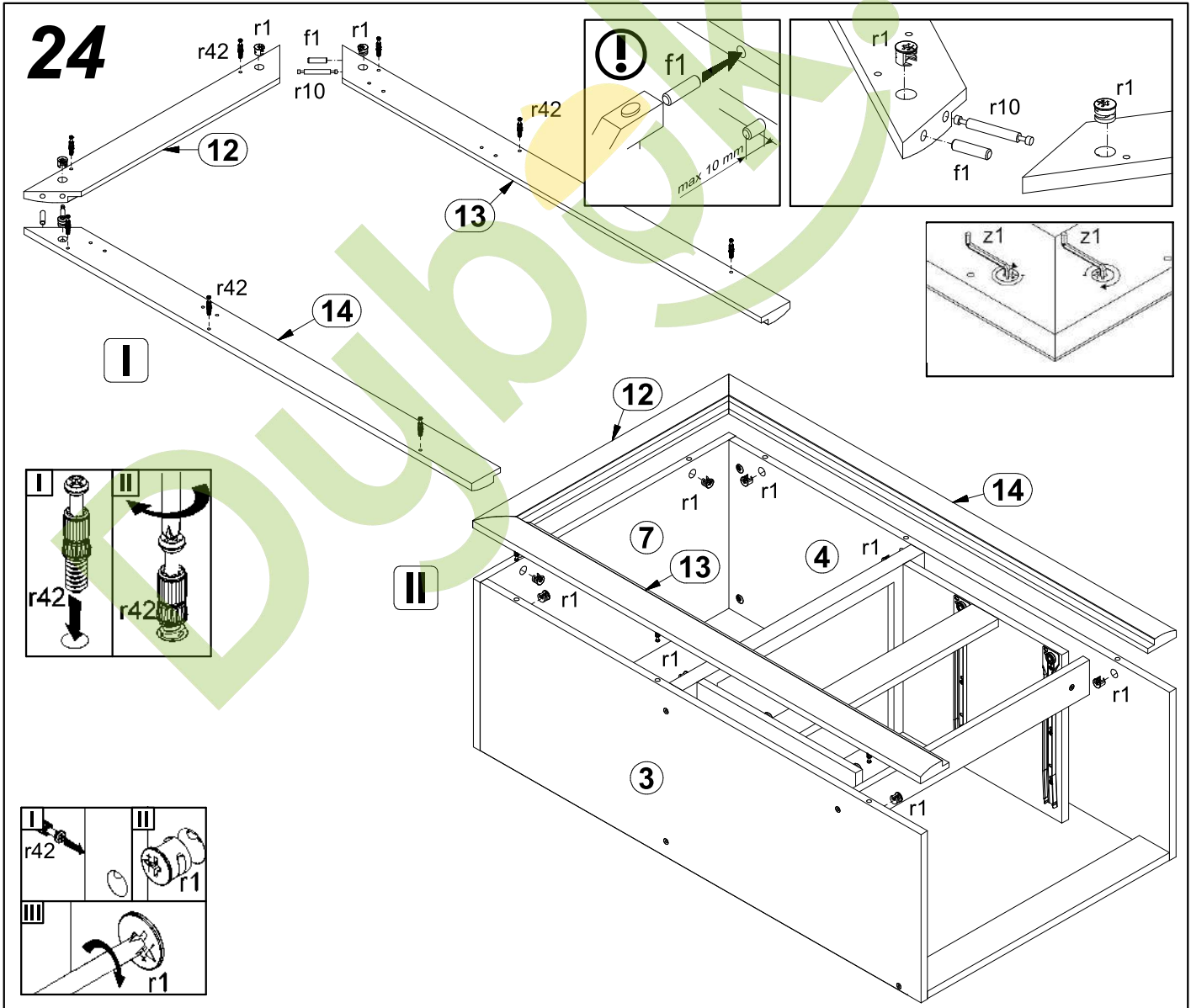
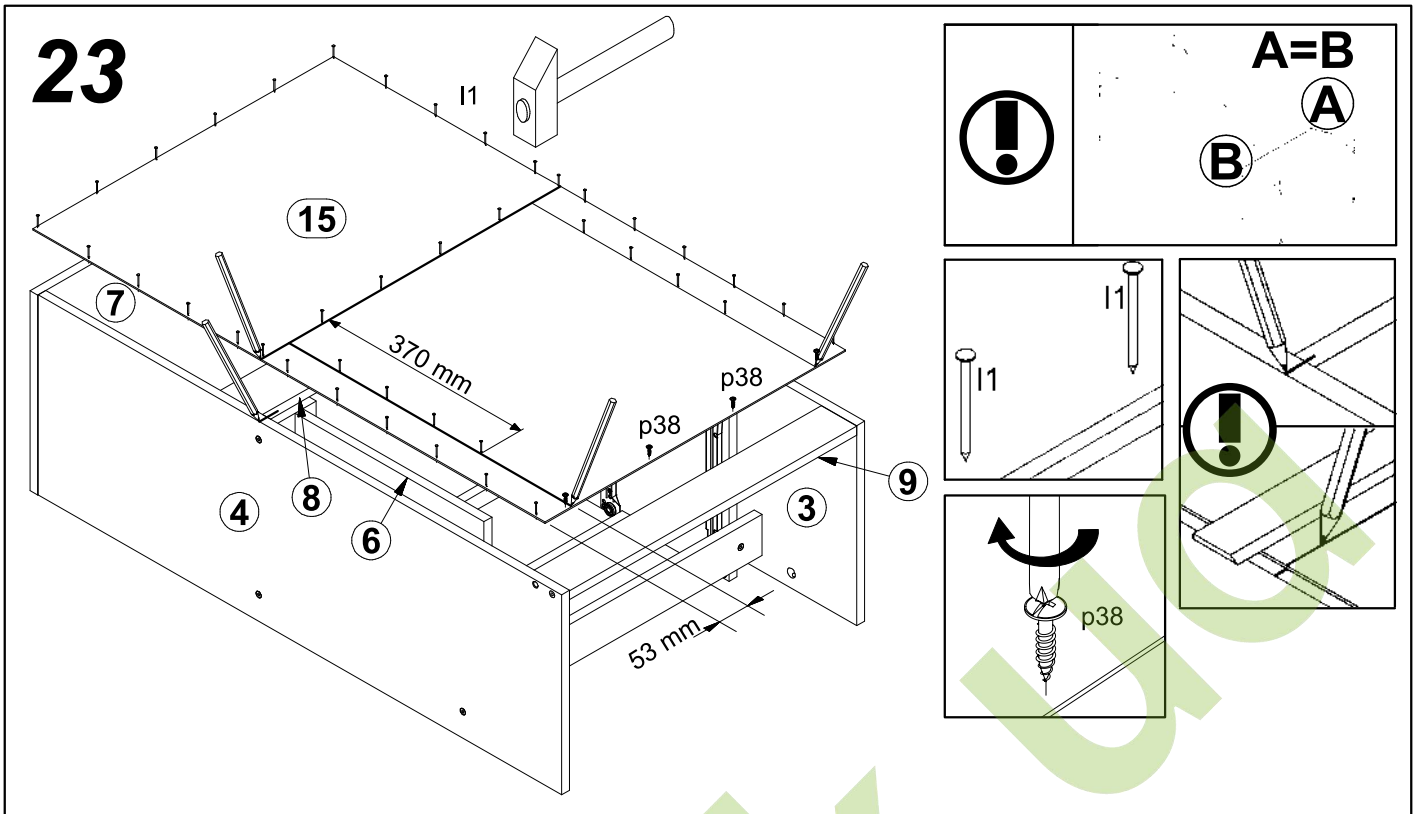

25

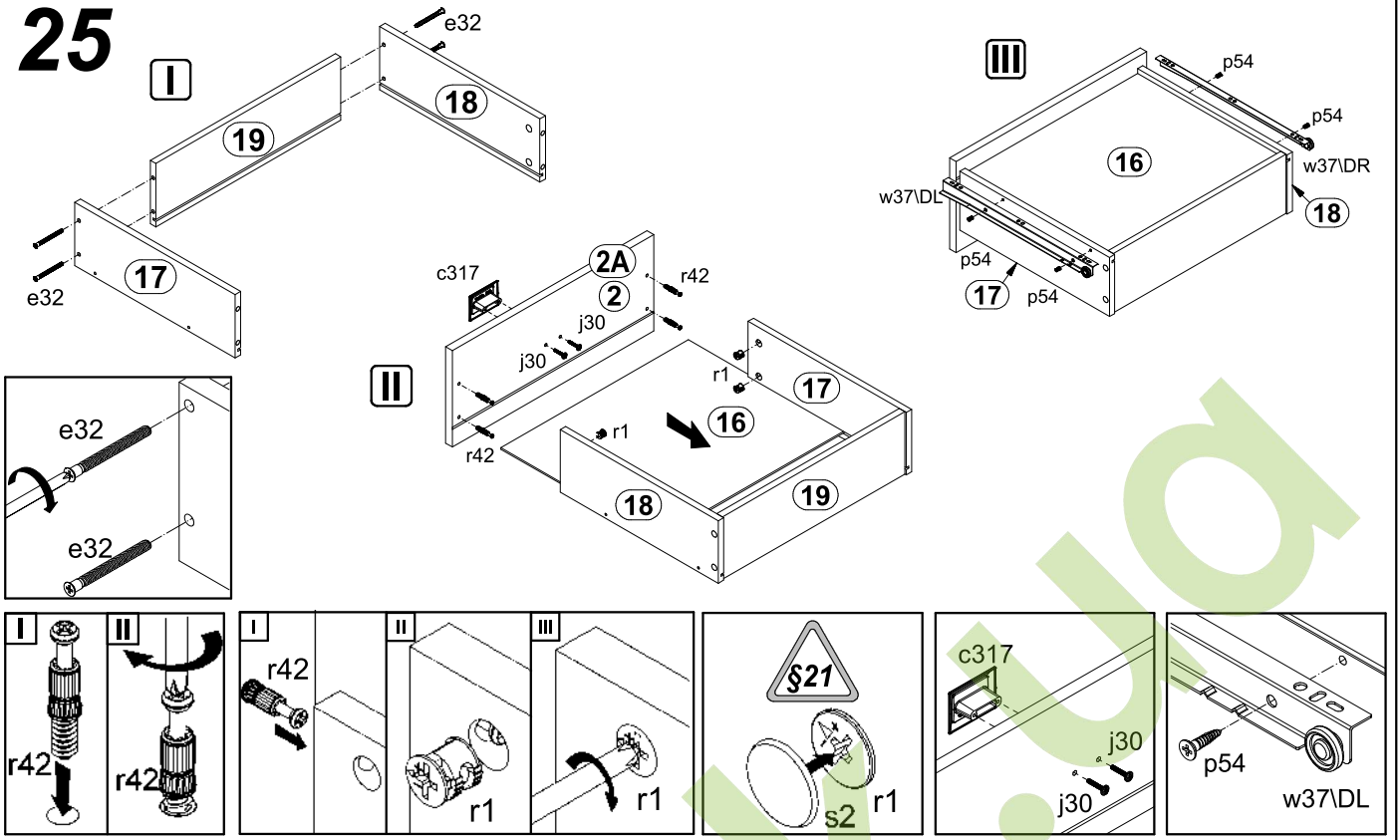

26

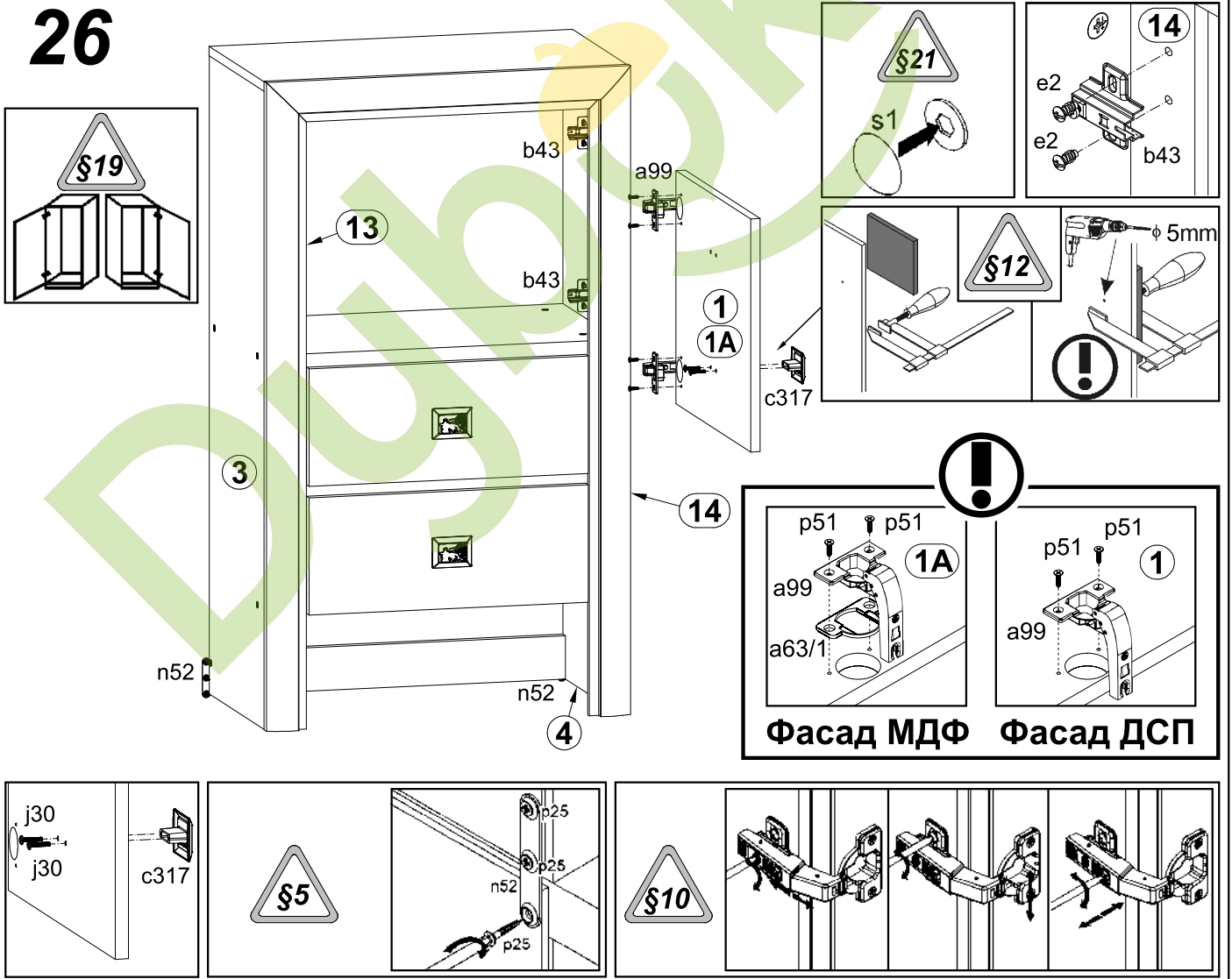

V Вітрина / Витрина **REG1D1W**



A	B	C	D
1	M111-003	1380	445 10/10
2	M111-004	445	465 9/10
2A	M111-004A	445	465 9/10
3	M111-105	1999	330 3/10
4	M111-106	1999	330 3/10
5	M111-305	547	330 3/10
6	M111-306	547	330 3/10
7	M111-314	547	330 3/10
8	M111-403	547	68 2/10
9	M111-508	2000	65 4/10
10	M111-509	2000	65 4/10
11	M111-510	581	65 4/10
12	M111-513	545	305 5/10
13	M111-906	1925	547 6/10

→ Фасад ДСП
→ Фасад МДФ

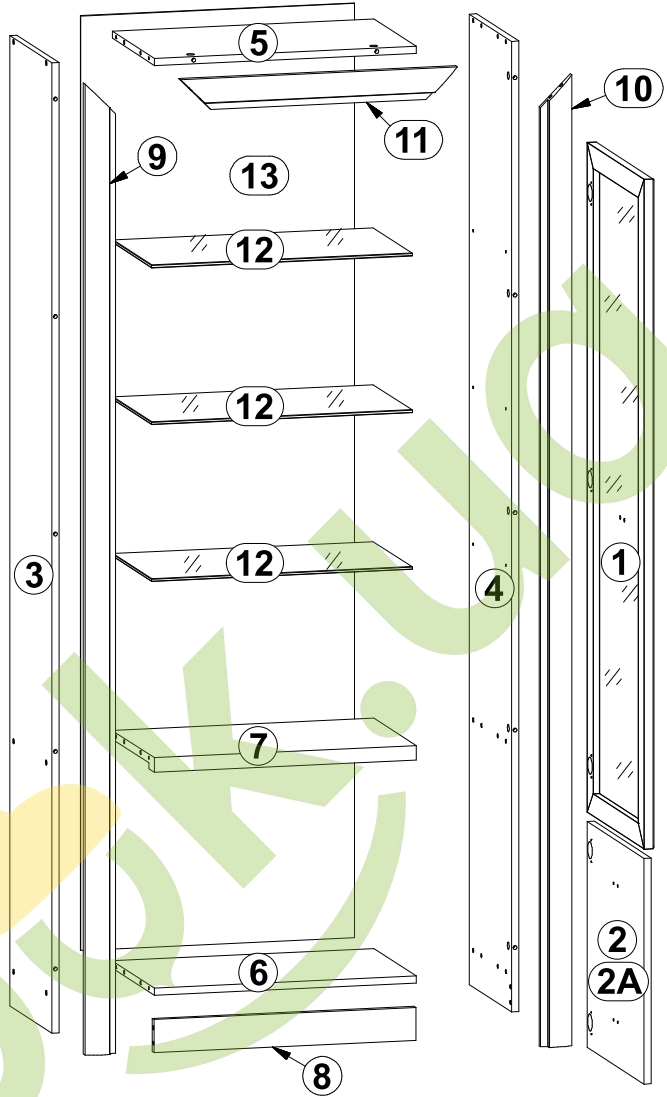

27

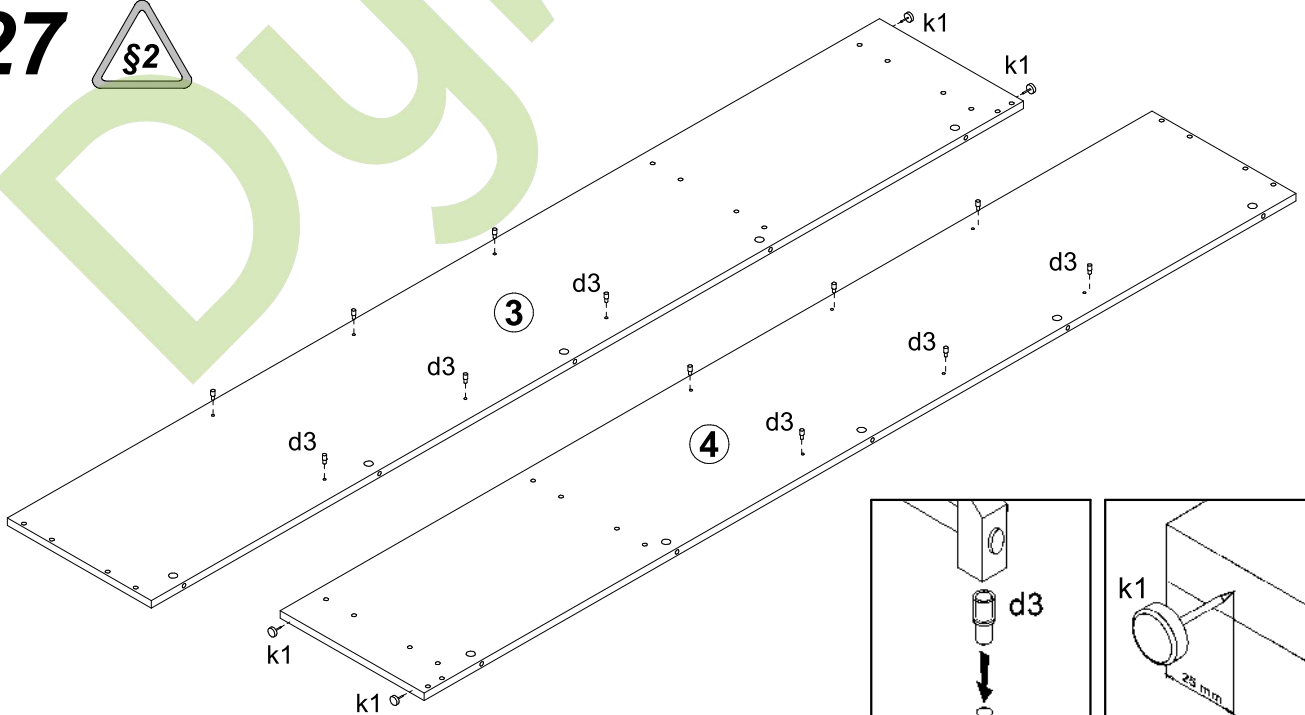

28

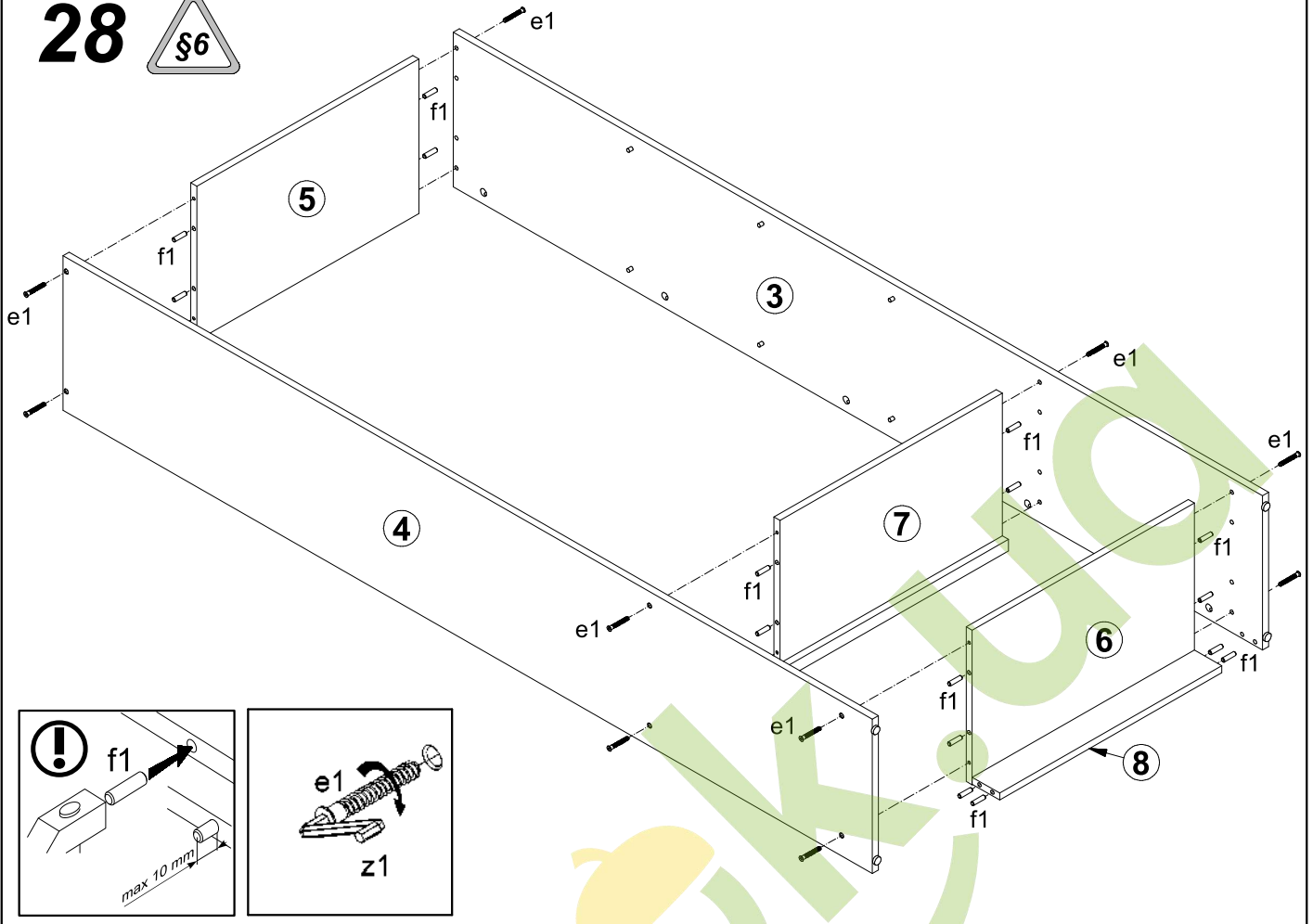

29

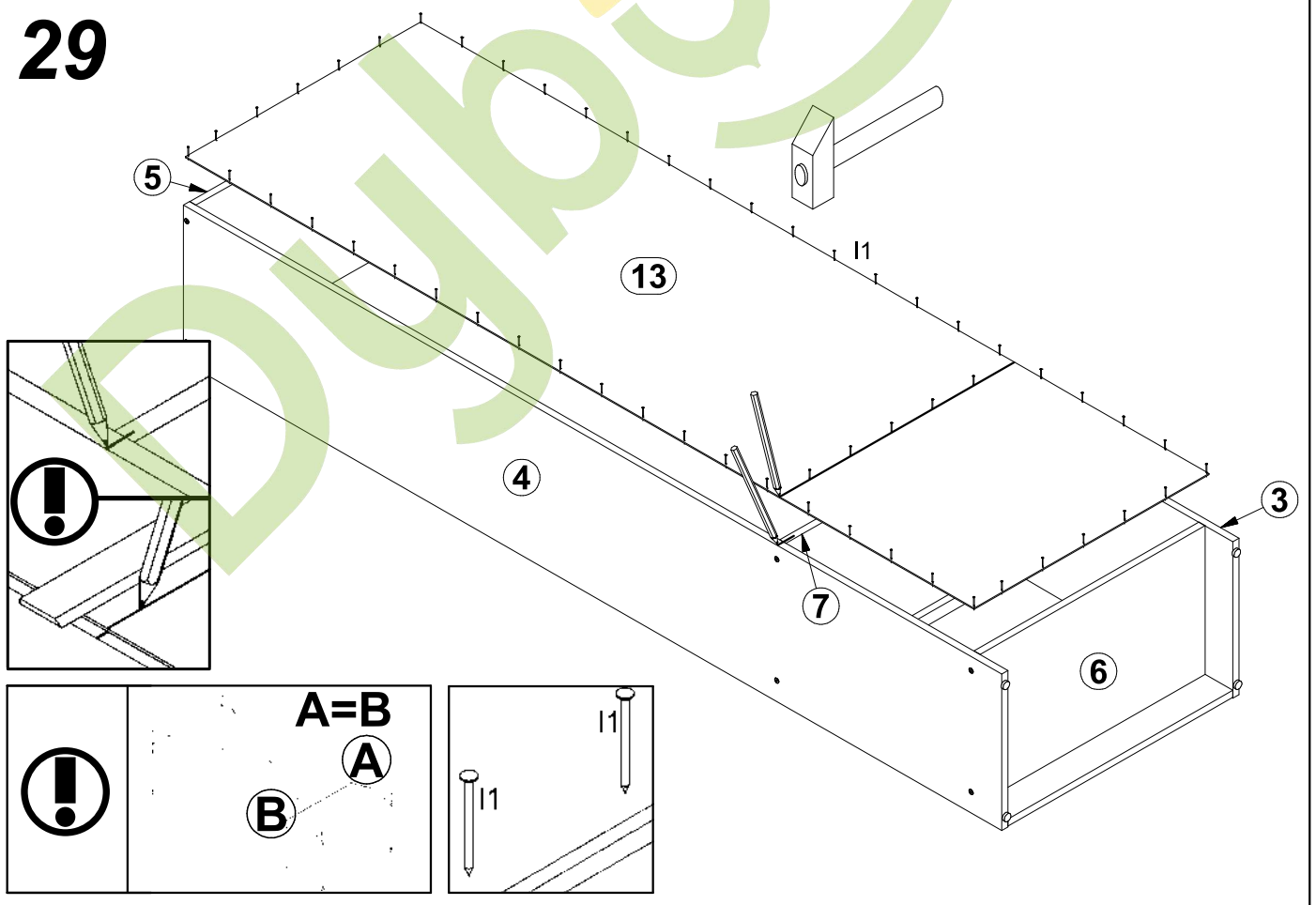

30

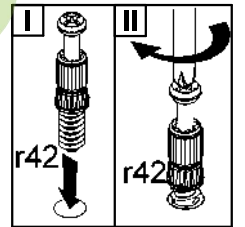
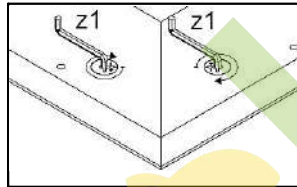
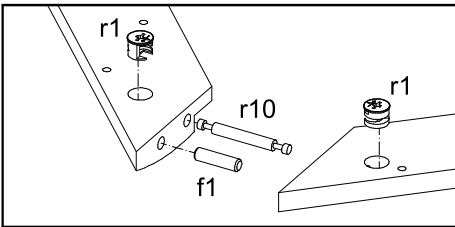
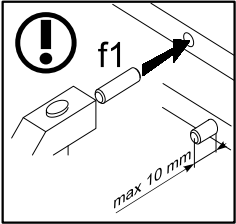
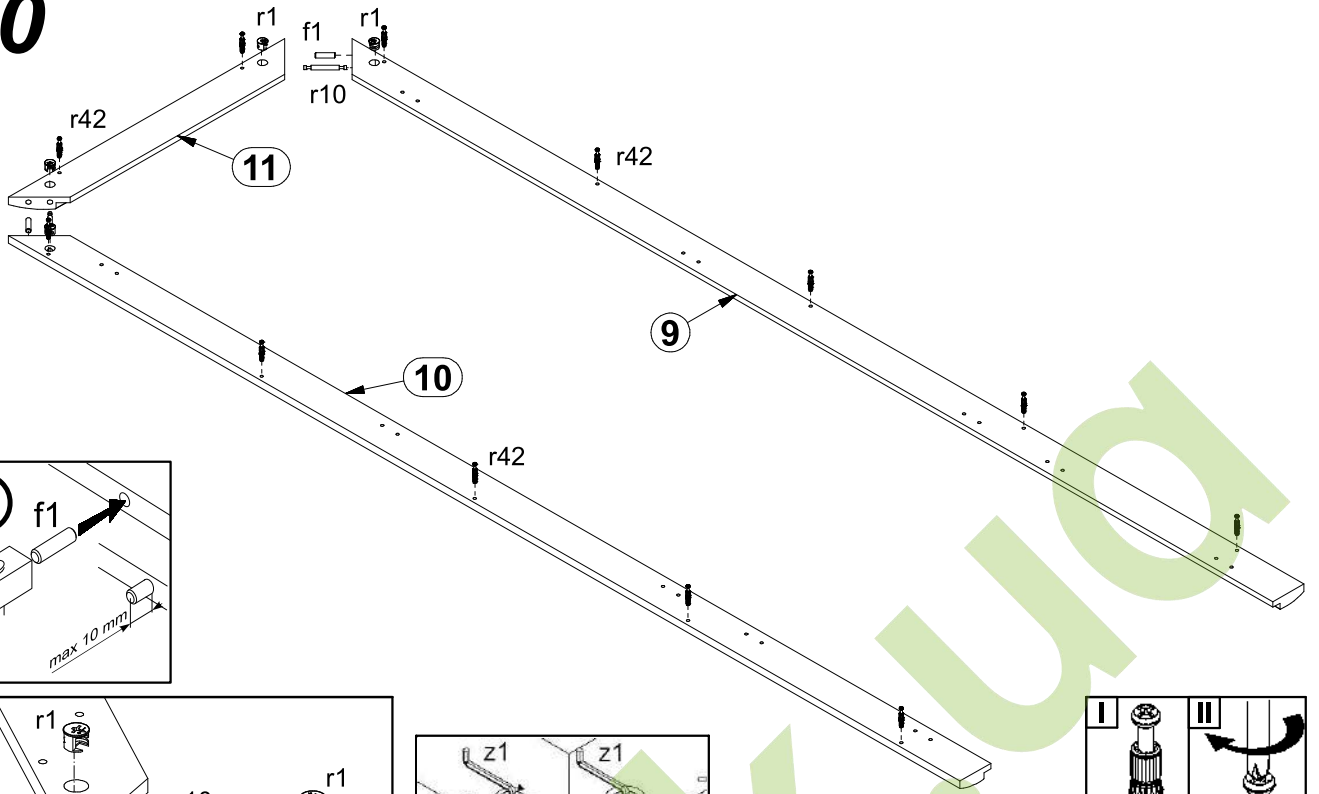

31

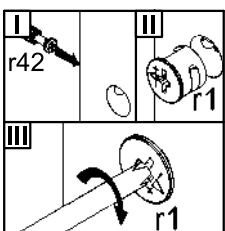
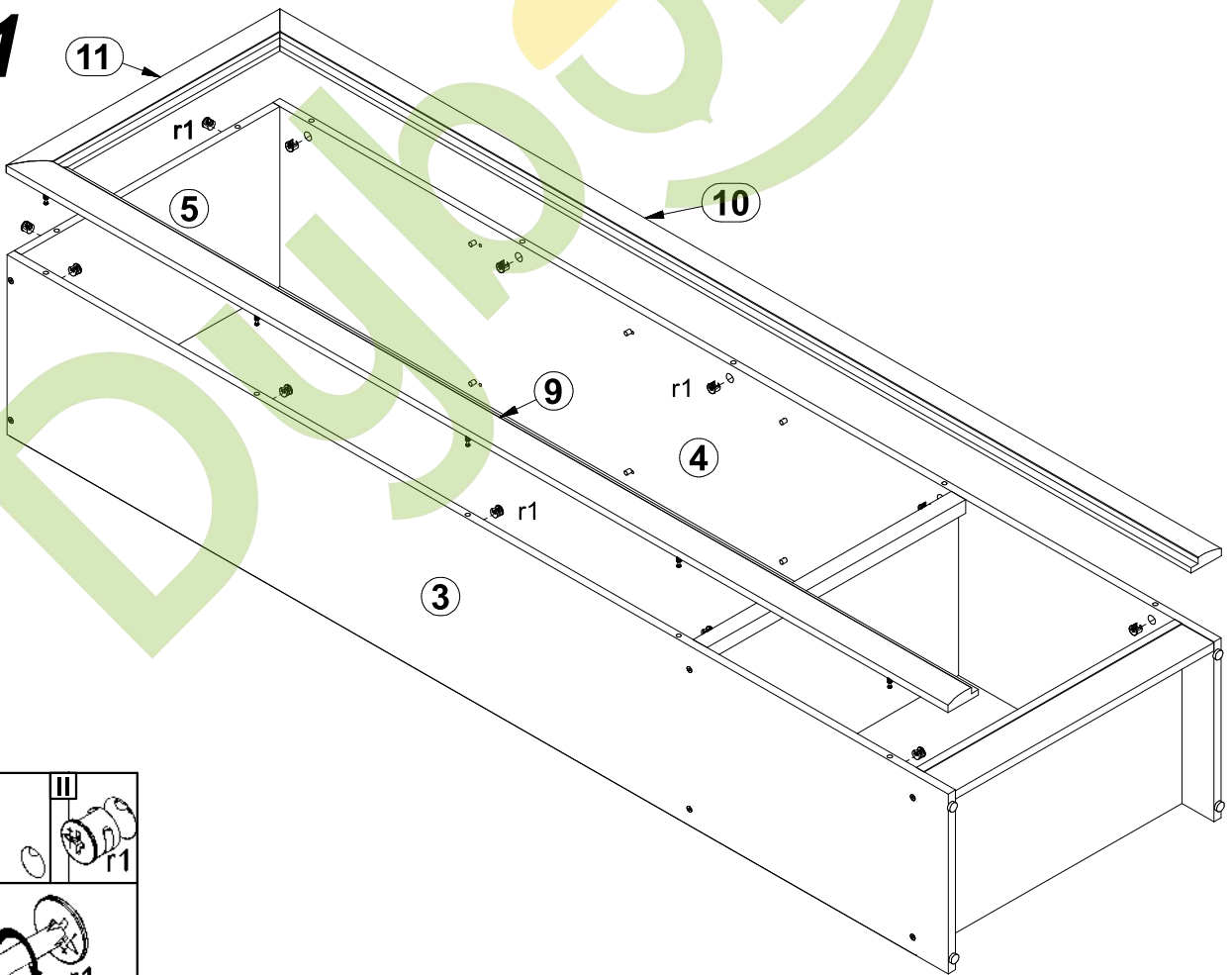

32 §11

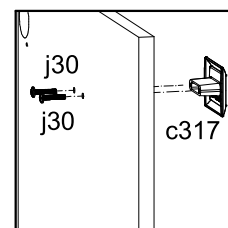
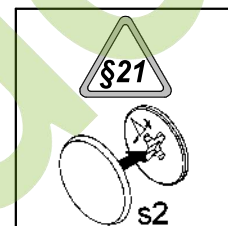
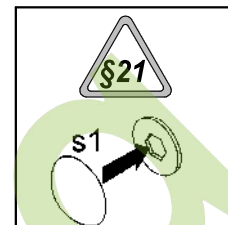
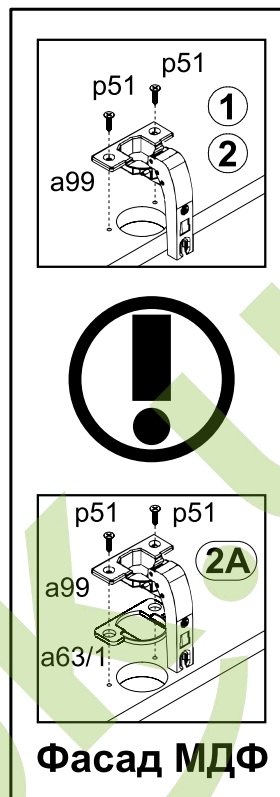
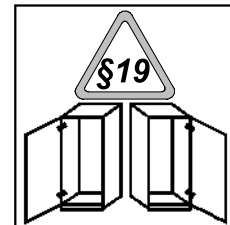

УВАГА!
При монтажі ручок вітрини **ОБОВ'ЯЗКОВО** ЗАСТОСУВАТИ ПРОКЛАДКИ o26 і o27!

ВНИМАНИЕ!
При монтаже ручек витрины **ОБЯЗАТЕЛЬНО** ПРИМЕНЕНИЕ ПРОКЛАДОК o26 и o27!

